



*Fire Your Imagination*

# Marlborough2

Balanced Flue Log Effect Stove Range

With Upgradeable Control Valve



## Instructions for Use, Installation & Servicing

For use in GB & IE (Great Britain & Republic of Ireland).

### **IMPORTANT**

**THE OUTER CASING, FRONT AND GLASS PANEL BECOME EXTREMELY HOT DURING OPERATION AND WILL RESULT IN SERIOUS INJURY AND BURNS IF TOUCHED. IT IS THEREFORE RECOMMENDED THAT A FIREGUARD COMPLYING WITH BS 8423 (LATEST EDITION) IS USED IN THE PRESENCE OF YOUNG CHILDREN, THE ELDERLY OR INFIRM.**

**ENSURE THAT ALL COMBUSTIBLE MATERIALS ARE NOT POSITIONED ABOVE OR NEAR TO THE APPLIANCE OUTER CASING.**

This product contains a heat resistant glass panel. This panel should be checked during Installation and at each servicing interval. If any damage is observed on the front face of the glass panel (scratches, scores, cracks or other surface defects), the glass panel must be replaced and the appliance must not be used until a replacement is installed. Under no circumstances should the appliance be used if any damage is observed, the glass panel is removed or broken.

It is essential that ALL of the screws that retain the glass frame are replaced and tightened correctly. Under no circumstances should the appliance be operated if any of these screws are loose or missing.

These Instructions must be left with the appliance for future reference and for consultation when servicing the appliance. Please make the customer aware of the correct operation of the appliance before leaving these instructions with them.

The commissioning sheet found on Page 3 of this Instruction manual must be completed by the Installer prior to leaving the premises.

# Contents

## Marlborough2 - Balanced Flue Log Effect Stove Range

Covering the following models:

Model	Small		Medium	
	NG	LPG	NG	LPG
<b>Marlborough2</b>	559-024	559-462	559-033	559-471

**Appliance Commissioning Checklist .....3**

**User Instructions .....4**

**Installation Instructions .....11**

Technical Specifications ..... 11

Site Requirements ..... 14

Installation ..... 18

Commissioning .....26

**Servicing Instructions.....27**

Fault Finding .....27

How to Replace Parts .....29

Spare Parts List.....36

Service Records .....39

Information Requirement - Gas Heaters .....40



If you have purchased your stove or fire from an authorised stockist within our Expert Retailer Network, then automatically your product will carry a 2 year warranty as standard. The 2 year warranty can be further extended to a total warranty period of 5 years by registering your Gazco Stove or Fireplace within one month of the latter of the purchase date or installation date. Accordingly, the start date for the warranty period is the date of purchase. During the registration process, the Expert Retailer details will be required for your Extended Warranty to be activated. Any product purchased outside of our Expert Retailer Network will carry a standard 12 month, non-extendable warranty.

It is a condition of the Extended Warranty that the installation complies with the relevant Building Regulations and is carried out by a suitably trained and qualified individual (GasSafe in the UK or equivalent in other countries) with the certificate of installation and the Commissioning Report on Page 3 completed and retained by the end user.

Full terms and conditions are detailed in the Warranty Statement on the Gazco website [www.gazco.com](http://www.gazco.com). In the event of any conflict of information the wording on the website shall prevail.

Important Note: Should any problems be experienced with your product, claims must first be submitted to the Expert Retailer where the appliance was purchased from who will offer immediate assistance or contact Gazco on your behalf.



**It is a requirement of the Building Regulations 2010 that the installation of this appliance is notified to the Local Authority. It is the responsibility of the GasSafe registered installer to carry out this notification to the Local Authority via the GasSafe register Competent Persons Scheme in England and Wales (different rules apply in Scotland and Northern Ireland).**

**When the installation has been notified, GasSafe will send a Building Regulations Compliance Certificate to you containing details of the work completed. Please ensure that the person responsible for the installation of this appliance completes this notification and records it in the Appliance Commissioning Checklist on page 3.**

**IT IS YOUR RESPONSIBILITY TO COMPLY WITH THE BUILDING REGULATIONS AND BE ABLE TO PRODUCE THIS CERTIFICATE SHOULD IT BE REQUIRED IN THE FUTURE.**

# Appliance Commissioning Checklist

To assist us in any guarantee claim please complete the following information:-

## IMPORTANT NOTICE

Explain the operation of the appliance to the end user, hand the completed instructions to them for safe keeping, as the information will be required when making any guaranteed claims.

FLUE CHECK	PASS	FAIL	
1. Flue Is correct for appliance			
2. Flue flow Test N/A			
3. Spillage Test N/A			
GAS CHECK			
1. Gas soundness & let by test			
2. Standing gas pressure	mb		
3. Appliance working pressure (on High Setting) Minimum Pressure Requirement: NG - 17.5mbar LPG - 34.5mbar NB All other gas appliances must be operating on full	mb		
4. Gas rate	m <sup>3</sup> /h		
5. Does Ventilation meet appliance requirements N/A			
6. Have controls been upgraded (Upgradeable models only)	8455 Standard	YES	NO
	8456 Programmable Thermostatic and Timer	YES	NO
SAFETY CHECK			
1. Check soundness of the Thermocouple connections - including tightness and lead integrity			
2. Glass checked to ensure no damage, scratches, scores or cracks			
3. Glass frame secured correctly and all screws replaced			
BUILDING CONTROL NOTIFICATION	YES	NO	
1. Installer notified GasSafe/Local Authority of installation via Competent Persons Scheme?			

## RETAILER AND INSTALLER INFORMATION

Retailer .....	Installation Company .....
.....	.....
.....	.....
Contact No.....	Engineer.....
Date of Purchase .....	Contact No.....
Model No. ....	GasSafe Reg No. ....
Serial No.....	Date of Installation .....
Gas Type .....	

# User Instructions

## Welcome

*Congratulations on purchasing your Gazco stove, if installed correctly Gazco hope it will give you many years of warmth and pleasure for which it was designed.*

*The purpose of this manual is to familiarise you with your appliance, and give guidelines for its installation, operation and maintenance. If, after reading, you need further information, please do not hesitate to contact your Gazco retailer.*

## WARNING



**In the event of a gas escape or if you can smell gas, please take the following steps:**

- **Immediately turn off the gas supply at the meter/emergency control valve**
- **Extinguish all sources of ignition**
- **Do not smoke**
- **Do not operate any electrical light or power switches (On or Off)**
- **Ventilate the building(s) by opening doors and windows**
- **Ensure access to the premises can be made**

**Please report the incident immediately to the National Gas Emergency Service Call Centre on 0800 111 999 (England, Scotland and Wales) , 0800 002 001 (N. Ireland) or in the case of LPG, the gas supplier whose details can be found on the bulk storage vessel or cylinder.**

**The gas supply must not be used until remedial action has been taken to correct the defect and the installation has been recommissioned by a competent person.**

## 1. General

- 1.1 Installation and servicing must only be carried out by a competent person whose name appears on the GasSafe register. To ensure the engineer is registered with GasSafe they should possess an ID Card carrying the following logo:



- 1.2 In all correspondence, please quote the appliance type and serial number which can be found on the data badge located at the rear of the appliance or on the Commissioning Checklist on Page 3.

- 1.3 **Do not** place curtains above the appliance: You must have 300mm clearance between the appliance and any curtains at either side.
- 1.4 The manufacturer considers the full outer casing of this stove to be a working surface and it will become hot whilst in operation. A suitable guard is recommended to protect young children, the aged and the infirm.
- 1.5 No furnishings or other objects should be placed within 1 metre of the front of the appliance.
- 1.6 If a shelf is fitted, a distance of 225mm above the appliance is required.
- 1.7 Do not attempt to burn rubbish in this appliance.
- 1.8 This appliance must only be operated with the door secured firmly in position. If any cracks appear in the glass the appliance must not be used until the glass panel is replaced.
- 1.9 If, for any reason, the flue has to be removed from the appliance, the seals must be replaced in the inner spigot.
- 1.10 Do not obstruct the flue terminal in any way i.e. by planting flowers, trees shrubs etc. in the near vicinity, or by leaning objects up against the terminal guard.
- 1.11 Do not put any objects on the terminal guard; it will lose its shape.
- 1.12 Do not use a garden sprinkler or hose near the terminal.
- 1.13 This product is guaranteed for 5 years from the date of installation, as set out in the terms and conditions of sale between Gazco and your local Gazco retailer. Please consult with your local Gazco retailer if you have any questions. In all correspondence always quote the Model Number and Serial Number.

## 2. Operating the Appliance

- 2.1 Locate the control valve on the appliance. It has two controls, see Diagram 1:
1. The right-hand knob controls the pilot ignition.
  2. The left-hand knob controls the main burner.

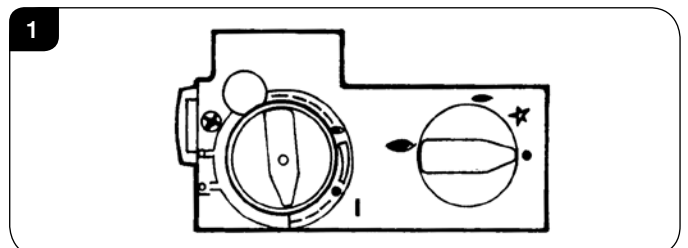

- 2.2 Refer to separate instructions if your appliance is upgraded to include battery remote control. The instructions below apply whether or not you have the remote upgrade.

# User Instructions

## Lighting the Pilot

- 2.3 To start the left-hand and right-hand control knobs must both point to off (●):
- 2.4 Press in the right-hand control knob and rotate anti-clockwise until a click is heard. Continue to press in. The knob points to the pilot (←).
- The pilot is lit.
- 2.5 Keep the knob depressed for 10 seconds before releasing. The pilot remains lit.
- Repeat the above steps if the pilot does not stay lit.
- NOTE: If the pilot goes out, the Interlock system prevents you lighting again for a short period.**
- 2.6 If, after repeating the above steps the pilot does not light, contact your Retailer or Installer.
- 2.7 Turn the right-hand knob to the left to main burner setting (↔).

## Adjusting the Flame height

- 2.8 You can now adjust the flame height and temperature using the left-hand control knob.
- 2.9 Turn the left-hand knob anti-clockwise to increase the flame height.
- 2.10 Turn clockwise to decrease the height.

**i** **IMPORTANT: YELLOW FLAMES TYPICALLY APPEAR WHEN THE APPLIANCE HAS REACHED NORMAL OPERATING TEMPERATURE. THIS CAN TAKE UP TO 30 MINUTES.**

**!** **WARNING: IF THE APPLIANCE FAILS TO LIGHT OR BECOMES EXTINGUISHED IN USE, WAIT 3 MINUTES BEFORE ATTEMPTING TO RELIGHT.**

## 3. Turning OFF the Appliance

- 3.1 To turn the main burner off turn the left-hand knob until it points to off (●). Just the pilot remains lit.
- 3.2 Press in and turn the right-hand knob until it points to off (●). The pilot goes out.

## 4. Upgrading the Appliance

- 4.1 The appliance is fitted with a control valve that can easily be upgraded to battery powered remote control. There are two versions of this control which can be obtained through your local Gazco retailer. There is no requirement for this upgrade to be carried out by an approved GasSafe engineer. However Gazco recommend that this task is undertaken by a suitably competent person.
- 4.2 This upgrade can be fitted before or after installation but if side clearances are limited then it will be easier to upgrade the appliance before installation. Full instructions are included with the kit.

**i** **If the appliance is left unattended for long periods of time (e.g. vacation), it is recommended to place the control valve in the Off or Pilot position.**

**Take care when leaving the appliance unattended, in exceptional circumstances sound waves from sources other than the transmitter can cause changes in the flame height adjustment.**

**DO NOT install two or more appliances using upgradeable controls in the same room, interference between the remote control frequencies can occur.**

## Standard Remote Control (PART NUMBER 8455)

- 4.3 This remote control can control the gas appliance after the pilot has been lit. It can turn the main burner on and regulate it from low through to high and back again. It can turn the main burner off leaving the pilot burning.

## Thermostatic and Timer Remote Control (PART NUMBER 8456)

- 4.4 This remote control can control the gas appliance after the pilot has been lit.

### MANUAL MODE

Can be used to turn the main burner on and manually regulate it from low through to high and back again. It can also be used to turn the main burner off leaving the pilot burning.

### AUTO MODE

Will automatically regulate the room to a pre-set temperature.

### TIMER MODE

Will turn the appliance on and off according to a pre-set programme and automatically regulate the room temperature during the two on periods.

# User Instructions

## 5. Cleaning the Appliance



**WARNING: NEVER CLEAN THE APPLIANCE WHILE IT'S HOT. THE APPLIANCE STAYS HOT FOR A LONG TIME AFTER SHUTDOWN.**

**IMPORTANT: THE OUTER PANNELLING AND DOOR OF THE APPLIANCE IS MADE FROM CAST IRON OR STEEL. TAKE CARE WHEN INSTALLING, REMOVING AND STORING TO AVOID DAMAGING THE OUTER CASING, HEARTH OR DOOR.**

- 5.1 Lift the front upwards until it is clear of the slots and pull away from the appliance, see Diagram 2.

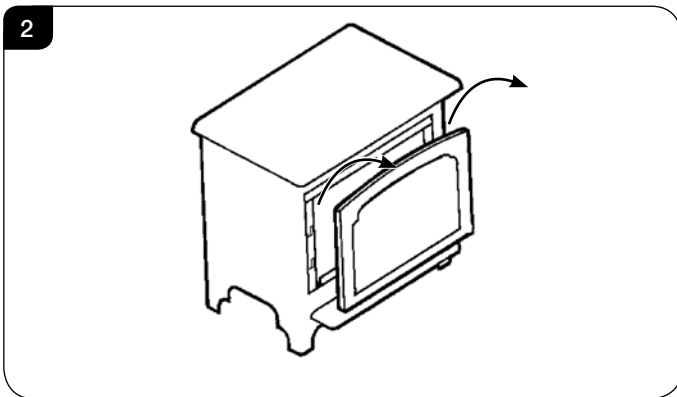

- 5.2 Remove the glass frame by undoing the fixing screws and lifting clear, see Diagram 3. **Take care to support the glass window panel when removing the screws.**

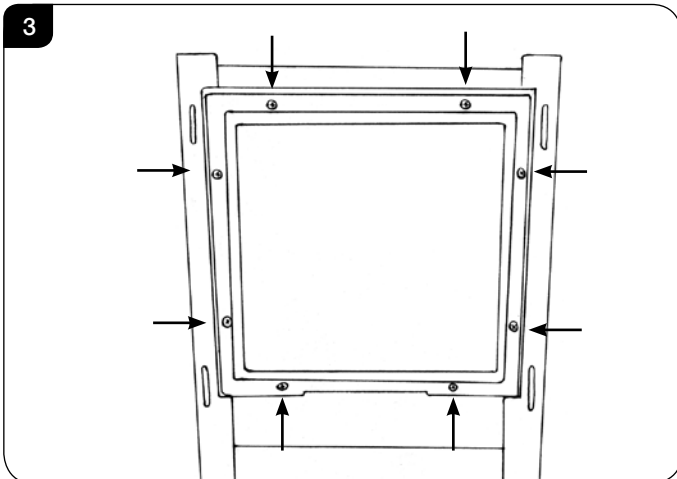

- 5.3 Place carefully to one side.
- 5.4 Carefully remove all of the ceramic logs, taking care when handling the front ash panels and set aside. Protect floor coverings and follow the advice give in Section 6.
- 5.5 The logs should not require cleaning. Do not use a vacuum cleaner or brush to clean the logs, any large pieces of debris may be removed by hand.

- 5.6 Ensure any debris is removed from the burner ports.
- 5.7 Replace the ceramics, see Section 7.
- 5.8 Ensure that the rope seal on the back of the glass frame is intact and replace the screws working from the top down. Tighten the screws evenly **DO NOT OVER TIGHTEN**, see Diagram 3.

**NEVER OPERATE THE APPLIANCE WHEN THE GLASS FRAME IS REMOVED OR BROKEN.**

- 5.9 Replace ALL of the securing screws ensuring that a screw is present in all fixing slots.



**UNDER NO CIRCUMSTANCES SHOULD THE APPLIANCE BE USED IF ANY OF THE GLASS FRAME RETAINING SCREWS ARE LOOSE OR MISSING.**

- 5.10 Use a damp cloth to clean the outer casing of the appliance.

## 6. Arrangement of Fuel Bed

### Advice on handling and disposal of fire ceramics



The fuel effect and side panels in this appliance are made from Refractory Ceramic Fibre (RCF), a material which is commonly used for this application.

Protective clothing is not required when handling these articles, but we recommend you follow normal hygiene rules of not smoking, eating or drinking in the work area and always wash your hands before eating or drinking.

To ensure that the release of RCF fibres are kept to a minimum, during installation and servicing a HEPA filtered vacuum is recommended to remove any dust accumulated in and around the appliance before and after working on it. When servicing the appliance it is recommended that the replaced items are not broken up, but are sealed within heavy duty polythene bags and labelled as RCF waste.

RCF waste is classed as stable, non-reactive hazardous waste and may be disposed of at a licensed landfill site.

Excessive exposure to these materials may cause temporary irritation to eyes, skin and respiratory tract; wash hands thoroughly after handling the material.

# User Instructions

## 7. Log Layout

- 7.1 Remove the cast iron door, see Section 5. Place carefully to one side. Remove the log guard by lifting vertically.



**WARNING: NEVER CLEAN THE APPLIANCE WHILE IT'S HOT. THE APPLIANCE STAYS HOT FOR A LONG TIME AFTER SHUTDOWN.**

**IMPORTANT: THE OUTER PANELLING AND DOOR OF THE APPLIANCE IS MADE FROM CAST IRON OR STEEL. TAKE CARE WHEN INSTALLING, REMOVING AND STORING TO AVOID DAMAGING THE OUTER CASING, HEARTH OR DOOR.**

### Small Marlborough2

All logs can be identified by a letter (A - E) on their underside. Logs B and E also have holes to locate each onto a burner stud.

- 7.2 Ensure the burner tray is clean and free from any debris, see Diagram 4.

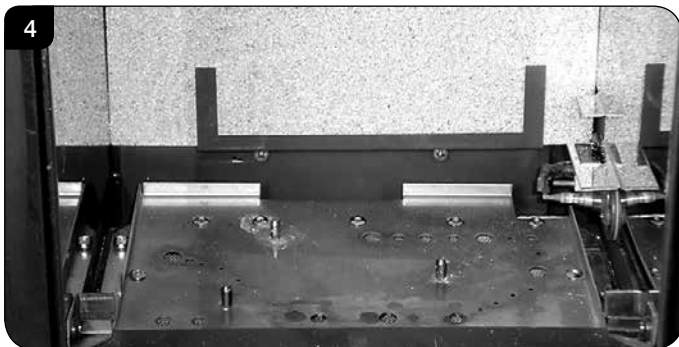

- 7.3 Place Log A on the higher rear bracket and push up against the back panel, see Diagram 5.

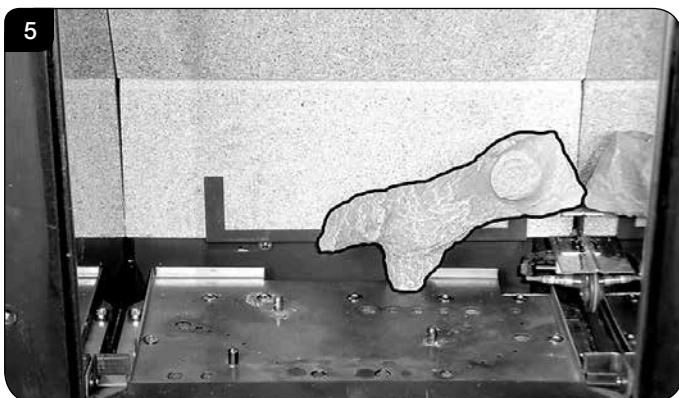

- 7.4 Place Log B over the two middle studs on the burner tray, see Diagram 6.

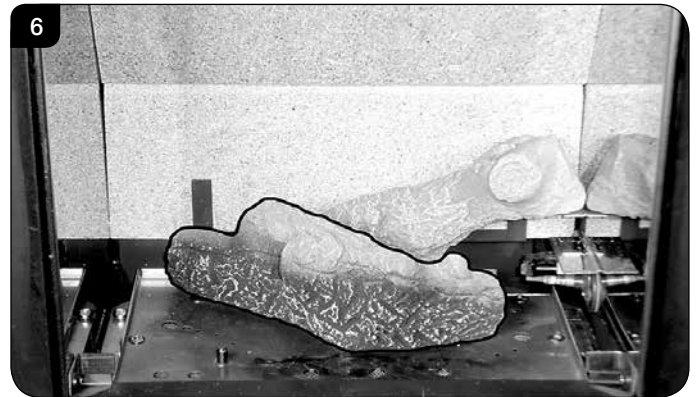

- 7.5 Place Log E onto the stud and behind the tag on the left hand side of the burner tray. Rest against Log B, see Diagram 7.

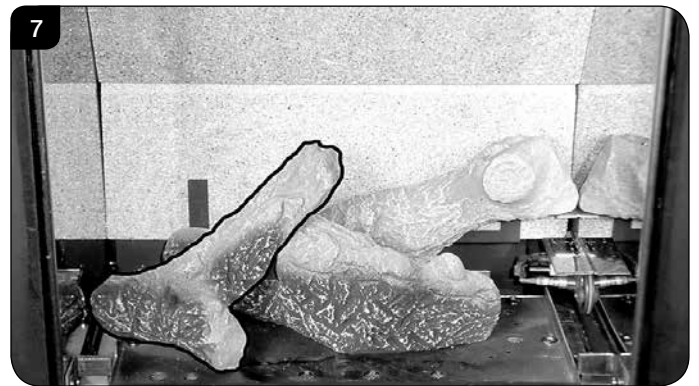

- 7.6 Place the small Ember at the front left of the firebox, against the rear of the log support bracket to obscure the reflection of the burner screw.

Place the larger Ember on the lower bracket above the pilot on the right hand side with the thicker edge facing the front and flat edges to the base and side, see Diagram 8.

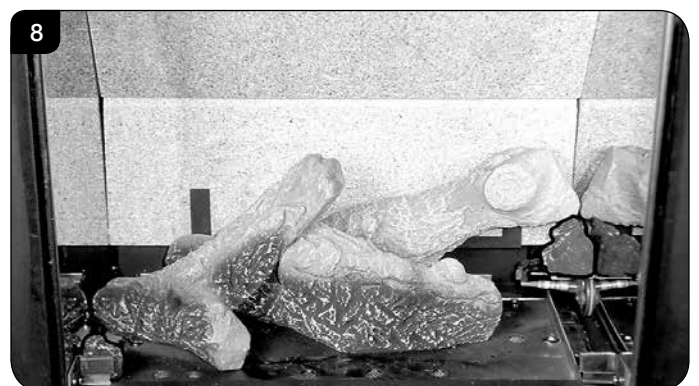

# User Instructions

- 7.7 Log C rests on the cutout on Log E and is pushed up to the side and rear of the firebox, see Diagram 9.



- 7.8 Place the pointed bottom of log D into the corner of the burner tray and rest on the location stud on log B, see Diagram 10.

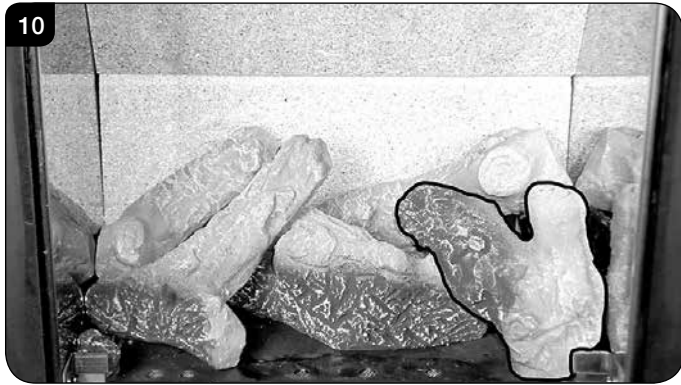

- 7.9 Sparingly spread an amount of the Embaglow fibres provided, covering the ports in the burner tray. Use a small piece in front of the log on the left hand side and a long strip in front of log B, see Diagram 11.

Take care not to use more than half a packet per application.

**WARNING - DO NOT PLACE NEAR THE PILOT AREA.**

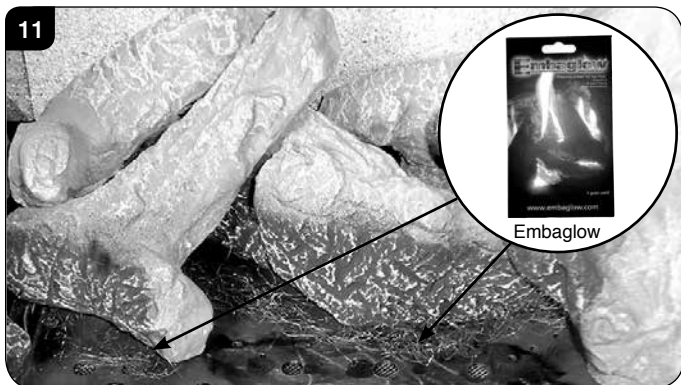

- 7.10 Lower log guard into position, see Diagram 12.



## Medium Marlborough2

The logs for the fuel bed are clearly individually labelled, A to D.

- 7.11 Ensure the burner tray is clean and free from any debris, see Diagram 13.

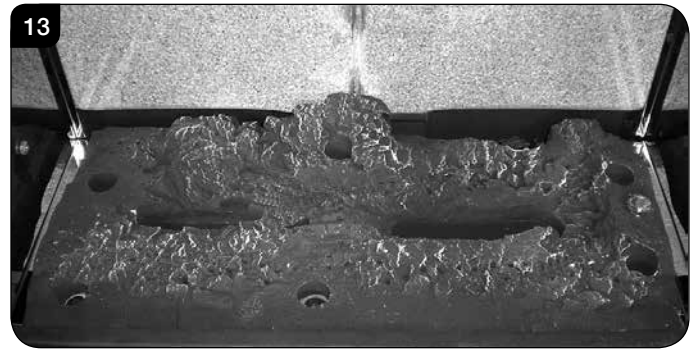

- 7.12 There are 3 embers. Place 2 embers in the back corners of the burner, resting in the cut outs, see Diagram 14. Place the last ember loosely at the front of the fuel bed to cover the hole in the centre.

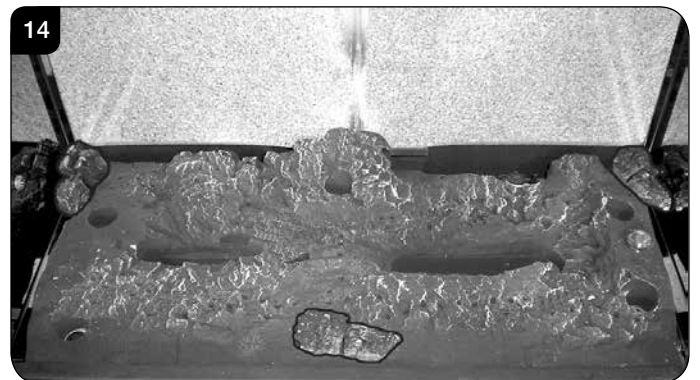



# User Instructions

- 7.13 Place Log D on the left hand side of the burner. There is a hole on the underside of Log D which fits over the raised stud on the left of the burner. The back of the log should rest flat against the back panel, see Diagram 15.

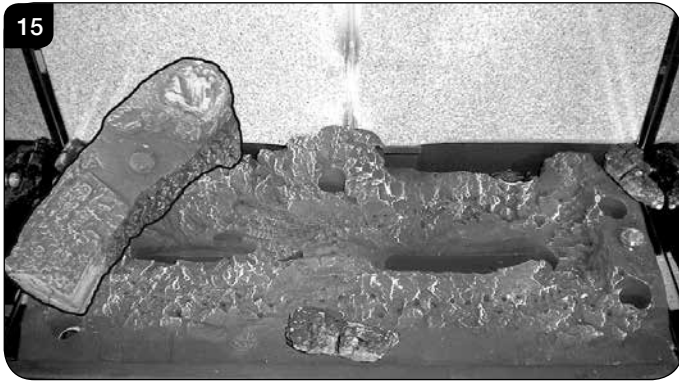

- 7.14 Place Log B on top of Log D. There is a hole on the underside of Log B which fits over the raised stud on Log D to secure in place. The right hand side of the log rests in the groove in the burner, see Diagram 16.

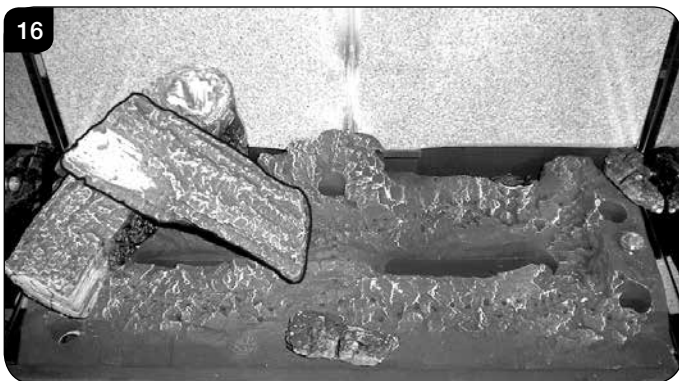

- 7.15 Place Log C on the right hand side of the burner. There is a hole on the underside of Log C which fits over the raised stud on the right of the burner. The back of the log should rest flush against the back panel, see Diagram 17.

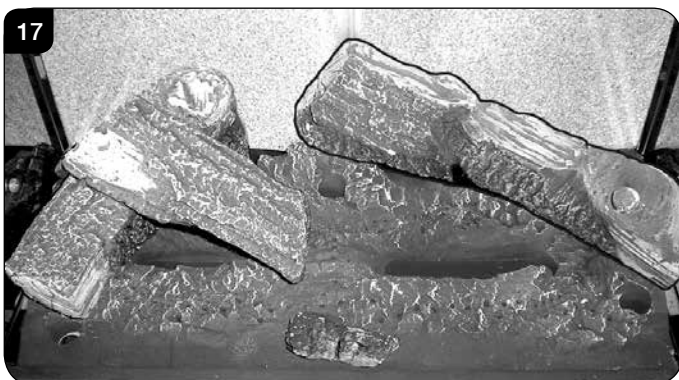

- 7.16 Place the log guard into position on the grooves on the sides of the firebox, see Diagram 18.

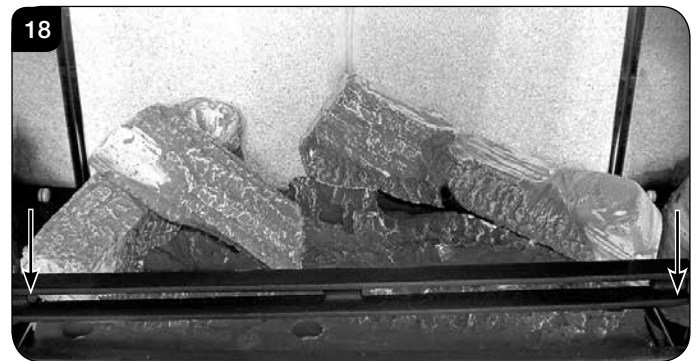

- 7.17 Place Log A across Log C. There is a hole on the underside of Log A which fits over the raised stud on Log C to secure in place. The small cut out on the left side of the log rests onto the log guard, see Diagram 19.



- 7.18 Once the logs are in place sparingly spread an amount of the Embaglow fibres provided on the sections highlighted, see Diagram 20.  
Take care not to use more than half a packet per application.  
**WARNING - DO NOT PLACE NEAR THE PILOT AREA.**

**IT IS ESSENTIAL TO KEEP THE REAR PORT FREE FROM OBSTRUCTION.**

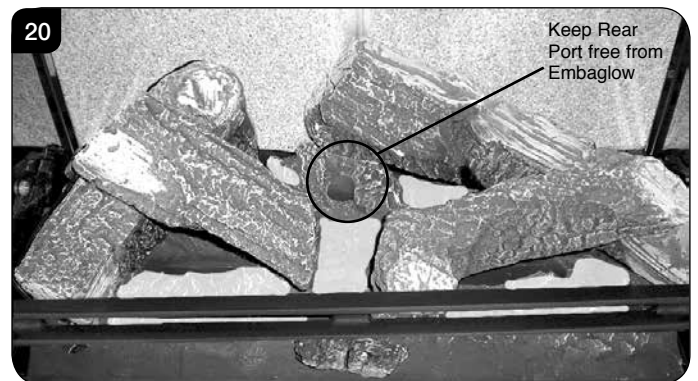

# User Instructions

- 7.19 Use a ceramic glass product generally sold for cleaning ceramic hobs to clean the glass front.

Refit the glass frame by tightening the fixing screws, see Diagram 21. Ensure that the rope seal on the back of the glass frame is intact.

**Take care to support the glass window panel when replacing the screws.**

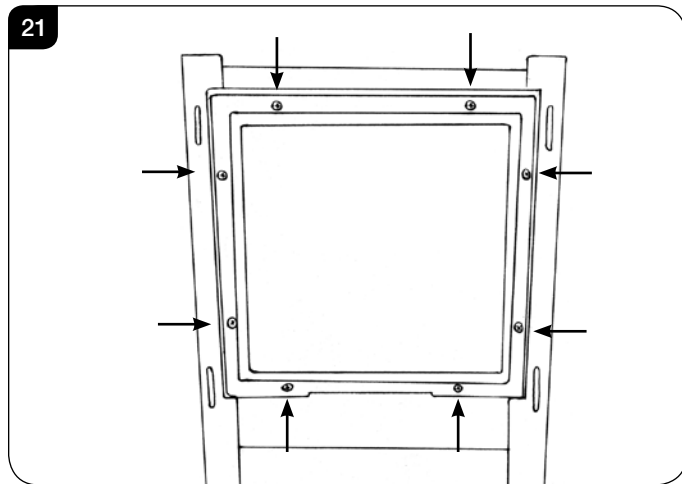

- 7.20 Locate the door on the 4 slots and secure to the firebox, see Diagram 22.

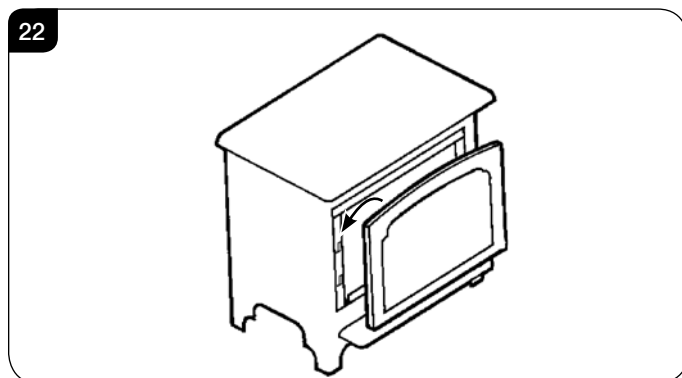

**NEVER OPERATE THE APPLIANCE WHEN THE DOOR IS REMOVED, OR THE GLASS IS BROKEN.**

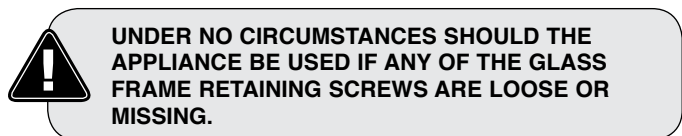

## 8. Flame Failure Device

- 8.1 This is a safety feature incorporated on this appliance which automatically switches off the gas supply if the pilot goes out and fails to heat the thermocouple.

**IF THIS OCCURS DO NOT ATTEMPT TO RELIGHT THE APPLIANCE FOR 3 MINUTES.**

## 9. Running In

- 9.1 During initial use of a new Gazco appliance a strong odour will be encountered as various surface coatings become hot for the first time. Although these odours are harmless it is recommended that the appliance is operated on maximum for 4 to 8 hours in order to fully burn off these coatings. After this period the odours should then disappear.

If the odours persists, please contact your installer for advice.

- 9.2 During the first few hours of burning there may be discolouration of the flames. This will also disappear after a short period of use.

## 10. Servicing

- 10.1 The appliance must be serviced every 12 months by a qualified GasSafe Engineer. In all correspondence always quote the Model number and the Serial number which may be found on the Commissioning Checklist (Page 3).

## 11. Ventilation

- 11.1 This appliance requires no additional ventilation.

## 12. Installation Details

- 12.1 Your installer should have completed the commissioning sheet at the front of this book. This records the essential installation details of the appliance. In all correspondence always quote the Model number and Serial number.

## 13. Hot Surfaces

- 13.1 Parts of this appliance become hot during normal use. Regard all parts of the appliance as a working surface, except for the control access panel.
- 13.2 Provide a suitable fire guard to protect young children and the infirm.

# Installation Instructions

## Technical Specification

Covering the following models:

Small Marlborough2		Medium Marlborough2	
NG	LPG	NG	LPG
559-024	559-462	559-033	559-471

Model	Gas Cat	Gas Type	Working Pressure	Aeration	Injector	Gas Rate m <sup>3</sup> /h	Input kW (Gross)		Country
							High	Low	
Small Marlborough2	I <sub>2</sub> H	Natural (G20)	20mbar	6mm x 6mm	185	0.305	3.2	2.0	GB, IE
	I <sub>3</sub> p	Propane (G31)	37mbar	8mm x 15mm	90	0.117	3.1	2.0	
Rear Exit Wall Thickness - Min 200mm/ Max 550mm									
Efficiency Class 1 - 82% / NOx Class 4									
Flue Outlet Size ø 150mm, Flue Inlet Size ø 100mm									
Gas Inlet Connection Size 8mm ø									

Model	Gas CAT.	Gas Type	Working Pressure	Aeration	Injector	Gas Rate m <sup>3</sup> /h	Input kW (Gross)		Country
							High	Low	
Medium Marlborough2	I <sub>2</sub> H	Natural (G20)	20mbar	2 x 9mm	390	0.628	6.6	3.9	GB, IE
	I <sub>3</sub> P	Propane (G31)	37mbar	2 x 18mm	185	0.248	6.6	3.7	
Rear Exit Wall Thickness - Min 200mm/ Max 550mm									
Efficiency Class 1 - 90.8% / NOx Class 4									
Flue Outlet Size ø 150mm, Flue Inlet Size ø 100mm									
Gas Inlet Connection Size 8mm ø									

**i** The net efficiency of this appliance has been measured as specified in EN613:2001 and the result after conversion to gross using the appropriate factor from Table E4 of SAP 2012 is 73.8% (Small) or 81.81% (Medium). The test data has been certified by Kiwa Nederland BV. The gross efficiency value may be used in the UK Government's Standard Assessment Procedure (SAP) for energy rating of dwellings.

# Installation Instructions

## Technical Specification

### Restrictor Tables

RESTRICTOR REQUIREMENT (MEDIUM ONLY) NAT. GAS				
VERTICAL & HORIZONTAL FLUE			TOP EXIT - VERTICAL ONLY INCLUDING OFFSET	
Vertical Flue Height	Horizontal Length	Restrictor Size	Vertical Flue Height	Restrictor Size
500mm - 999mm	Up to 1000mm	Ø 80mm	2000mm - 2999mm	Ø 52mm (Sliding)
1000mm - 1499mm	Up to 1000mm	Ø 70mm	3000mm - 5999mm	Ø 47mm (Sliding)
1500mm - 3000mm	Up to 2000mm	Ø 60mm	6000mm - 10000mm	Ø 40mm (Sliding)
1500mm - 3000mm	2000mm - 5000mm	Ø 70mm		

RESTRICTOR REQUIREMENT (MEDIUM ONLY) LPG				
VERTICAL & HORIZONTAL FLUE			TOP EXIT - VERTICAL ONLY INCLUDING OFFSET	
Vertical Flue Height	Horizontal Length	Restrictor Size	Vertical Flue Height	Restrictor Size
500mm - 999mm	Up to 1000mm	N/A	2000mm - 5999mm	Ø 52mm (Sliding)
1000mm - 1499mm	Up to 1000mm	Ø 80mm	6000mm - 10000mm	Ø 47mm (Sliding)
1500mm - 3000mm	Up to 2000mm	Ø 70mm		
2000mm - 3000mm	2000mm - 5000mm	Ø 80mm		

# Installation Instructions

## Technical Specification

This appliance has been certified for use in countries other than those stated. To install this appliance in these countries, it is essential to obtain the translated instructions and in some cases the appliance will require modification. Contact Gazco for further information.

### PACKING CHECKLIST

Qty Description	Fixing Kit containing:-
1 x Appliance	<b>Small:</b>
1 x Flue Blanking plate	1 x Instruction manual
1 x Log Guard	1 x Pozi Screw
1 x Log set	2 x Wood screw
1 x Ash Panel	2 x Wallplug
1 x Embaglow	
*Packed in appliance	<b>Medium:</b>
	1 x Instruction manual
	2 x Wood Screw
	2 x Wallplug
	1 x 80mm Restrictor
	1 x 40mm Restrictor

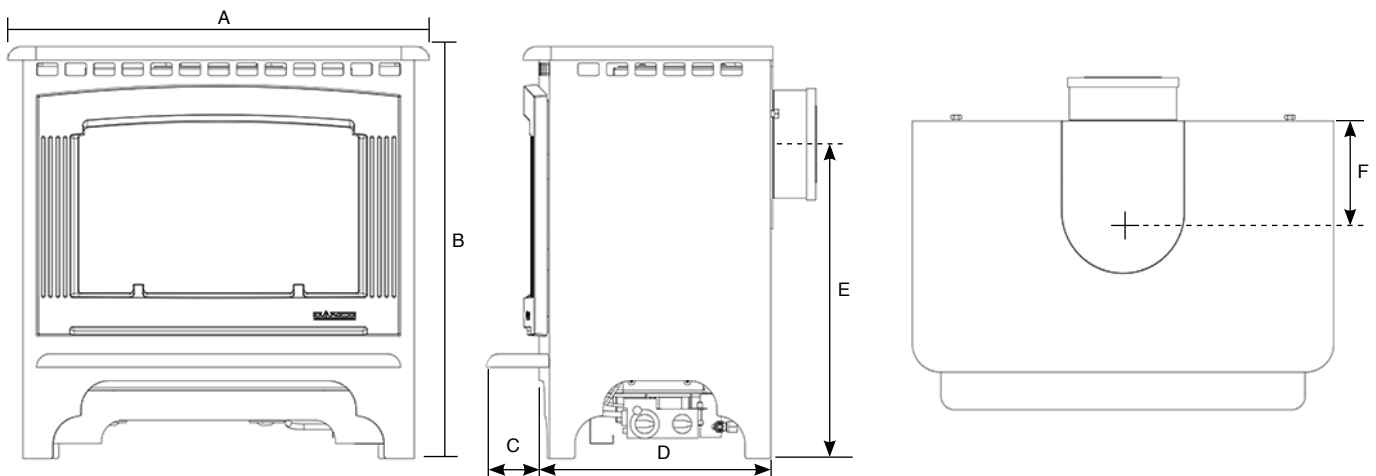

	A	B	C	D	E	F
<b>Small Marlborough2</b>	429	533	75	280	369	110
<b>Medium Marlborough2</b>	600	583	76	330	445	129

# Installation Instructions

## Site Requirements

### 1. Flue and Chimney Requirements

**Note: This appliance must only be installed with the flue supplied.**

You must adhere to the following:

- 1.1 The flue must be sited in accordance with BS5440: Part 1 (latest edition), see Diagram 1.
- 1.2 Fit a guard to protect people from any terminal less than 2 metres above any access such as level ground, a balcony or above a flat roof.
- 1.3 All horizontal flues must be securely fixed and fire precautions followed in accordance with local and national codes of practice.
- 1.4 A restrictor may be required. Refer to Technical Specifications on page 12.

### 2. Timber Framed Buildings

- 2.1 To prevent a fire hazard, you must provide additional clearance when the appliance passes through a wall containing any combustible materials.
- 2.2 A steel sleeve must be inserted into the hole through which the flue passes to give an air gap of 25mm between the sleeve and any outside surface of the flue.
- 2.3 Contact your local buildings authority for further guidance on installing gas fires in timber framed buildings.

**Note: Make sure you provide adequate clearance at the sides and back of the appliance for servicing access.**

#### 1 UK Dimensions

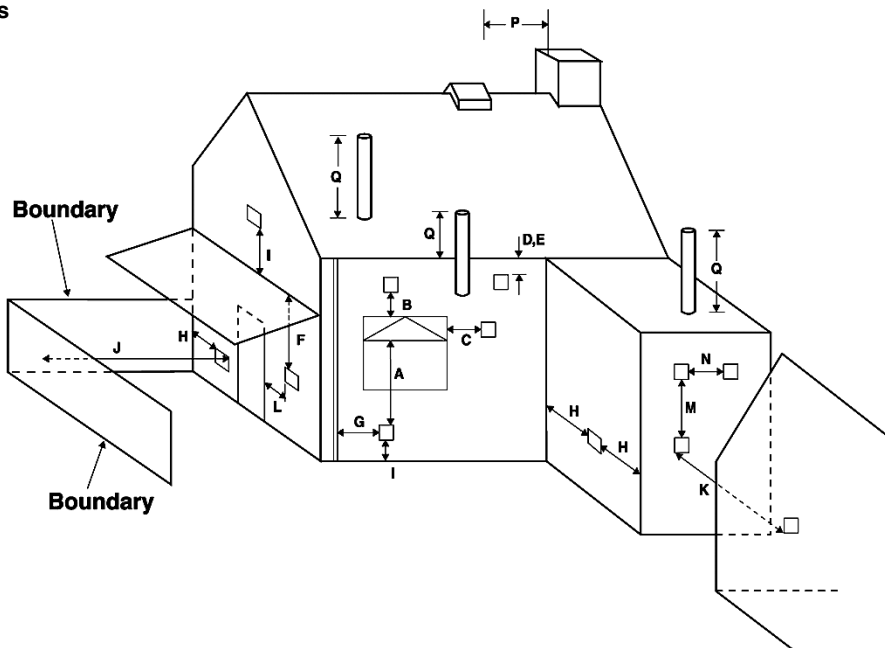

Dimension	Terminal Position	Minimum Distance
A*	Directly below an opening	600mm
B*	Above an opening	300mm
C*	Horizontally next to an opening	400mm
D	Below gutters, soil pipes or drain pipe	300mm
E	Below eaves	300mm
F	Below balcony or car port roof	600mm
G	From a vertical drain pipe or soil pipe	300mm
H	From an internal or external corner or to a boundary alongside the terminal	600mm
I	Above ground, roof or balcony level	300mm

Dimension	Terminal Position	Minimum Distance
J	From a surface or boundary facing the terminal	600mm
K	From a terminal facing the terminal	600mm
L	From an opening in the car port (e.g. door, window) into the dwelling	1200mm
M	Vertically from a terminal on the same wall	1200mm
N	Horizontally from a terminal on the same wall	300mm
P	From a structure on the roof	600mm
Q	Above the highest point of intersection with the roof	300mm

\* In addition, the terminal should not be nearer than 300mm to an opening in the building fabric formed for the purpose of accommodating a built-in element such as a window frame.

# Installation Instructions

## Site Requirements

### 3. Rear Flue (8526)

2

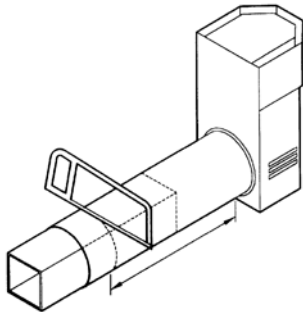

Terminal dimensions:  
395 x 200 x 200 mm (H x W x D)  
Guard supplied  
Cut to length as required on site (see Diagram 2).

### 4. Top Exit Flues Marlborough2 Medium only

There are two types of flue terminal: horizontal and vertical.  
For vertical see Section 4D.

#### 4a. For horizontal terminal installations

- 4.1 Decide on the terminal position.
- 4.2 Measure the height from the top of the appliance to the centre of the required hole. For minimum and maximum dimensions see Diagram 3.
- 4.3 To fit the flue you must have access to the top or the side of the appliance to connect the flue.
- 4.4 Assemble the vertical sections making sure the top plate and flue collar are fitted before the flue pipe.
- 4.5 Add the 90° elbow.
- 4.6 Add the horizontal section and terminal. **Only the horizontal part can be reduced in size.**
- 4.7 A masonry installation requires the addition of a suitable lintel to support the opening. Refer to Installation Instructions, Technical Information for details of the flue length.

#### 4b. Top Flue Up and Out Kit

- 4.8 This flue rises vertically from the top of the appliance, then continues horizontally outward, see Diagram 3.

The basic kit comprises:

#### Marlborough2 Medium 8509/8509AN

- 1 x 500mm vertical length
- 1 x 200mm vertical length
- 1 x 500mm terminal length
- 1 x 90 degree elbow
- 1 x wall plate
- 1 x 60mm/70mm/75mm restrictor
- 4 x fixing screws

3

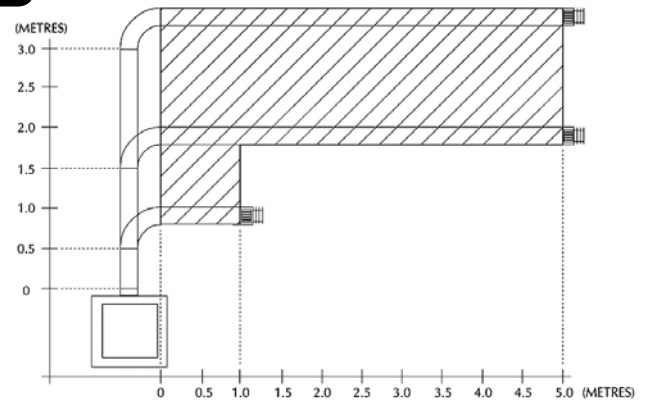

- 4.9 This kit provides the minimum materials. Extra lengths can be added to the vertical and horizontal sections; refer to Section 5.
- 4.10 Refer to Installation Instructions, Technical Specification to identify when to use a restrictor.

#### 4c. Top Flue Up and Out with Additional Bend

- 4.11 An additional bend can be used on the horizontal section (45° or 90°) but the overall horizontal flue is reduced, see Diagram 4.

4

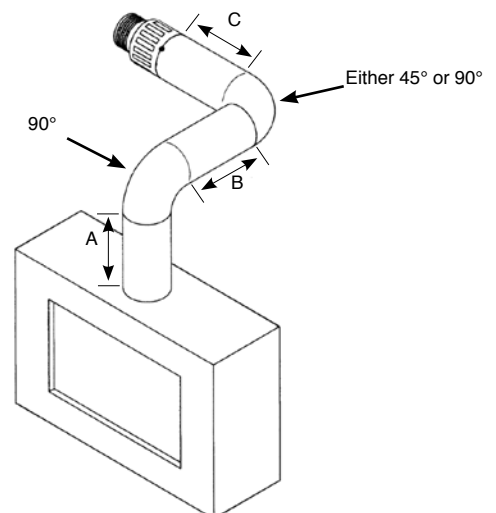

When A = 1.0 to 1.499 metres (No restrictor)  
B+C = 1.0 metre max

When A = 1.499 to 3.0 metres (75mm diameter restrictor)  
B+C = 4.0 metres max

# Installation Instructions

## Site Requirements

### 4d. Top Flue Vertical Kit (999-539/999-539AN)

4.12 This flue is vertical from the top of the appliance, see Diagram 5. A minimum vertical rise of 2m (6'56") to a maximum of 10m (32'10").

The basic kit comprises:

- 2 x 1m lengths
- 1 x 1m terminal lengths
- 1 x 52mm restrictor (sliding plate assembly)
- 1 x 47mm restrictor (sliding plate assembly)

#### ALL MODELS

- 4.13 Extra lengths can be added, see Diagram 5.
- 4.14 Refer to Installation Instructions, Technical Specification to identify when to use a restrictor.

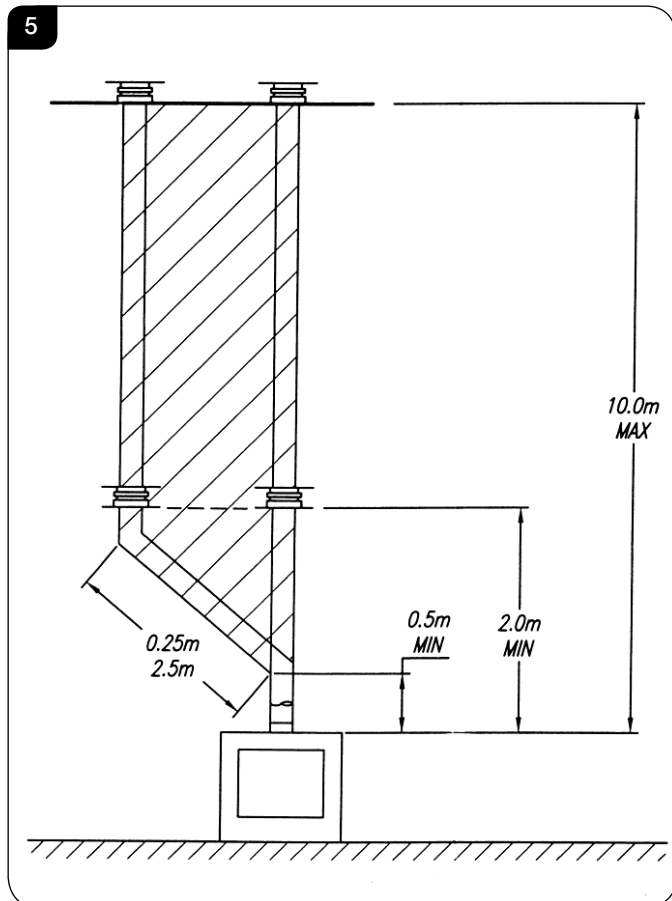

### 4e. Top Flue Vertical Offset Kit (8530/8530AN)

4.15 Used with kit 999-539. A minimum rise of 500mm (19½") is required to the first bend, see Diagram 5.

### 5. Optional Extra Flue Lengths and Bends

Nominal Length	Actual Length	Stainless Finish	Anthracite Finish
200mm	140mm	8527	8527AN
500mm	440mm	8528	8528AN
1000mm	940mm	8529	8529AN
45° Bend	N/A	8507	8507AN
90° Bend	N/A	8508	8508AN
Optional Flue Collar		8548MB	

### 6. Gas Supply

**THIS APPLIANCE IS INTENDED FOR USE ON A GAS INSTALLATION WITH A GOVERNED METER.**

- 6.1 Before installation, ensure that the local distribution conditions (identification of the type of gas and pressure) and the adjustment of the appliance are compatible.
- 6.2 Ensure the gas supply delivers the required amount of gas and is in accordance with the rules in force.
- 6.3 Soft copper tubing and soft soldered joints can be used but must not be closer than 50mm (2") to the underside of the firebox.
- 6.4 A means of isolating the gas supply to the appliance must be provided independent of any appliance control.
- 6.5 All supply gas pipes must be purged of any debris that may have entered prior to connection to the appliance.
- 6.6 The gas supply must be installed in a way that does not restrict the removal of the appliance for servicing and inspection.



# Installation Instructions

## Site Requirements

### 7. Appliance Location

- 7.1 Building Regulations state this appliance must stand on a non-combustible hearth that is at least 12mm thick and projects 50mm minimum from the base of the appliance in all directions, however Gazco recommend the hearth extends to the following dimensions, see Diagram 6.

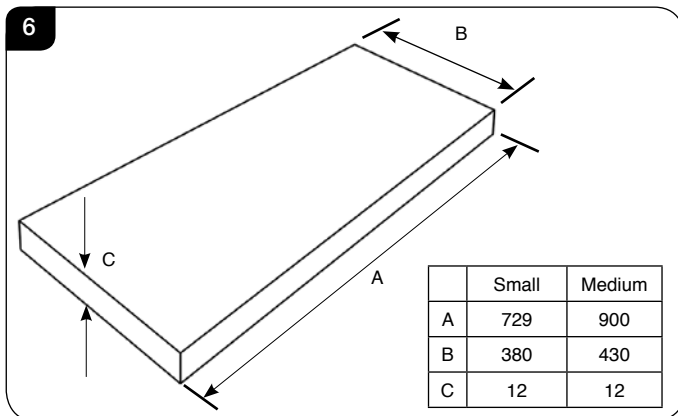

**i** **IMPORTANT: SMALL APPLIANCES HAVE REAR EXIT FLUES AND MUST BE INSTALLED ON AN EXTERNAL WALL.**

#### MINIMUM CLEARANCE

- 7.2 The appliance is not suitable for installation against a combustible wall.
- 7.3 Ensure that all minimum clearances to combustible materials are complied with, see Diagrams 7 and 8.

The specified clearances provide the minimum distance to combustible materials. If the appliance is intended to be installed into a non-combustible opening the clearance to the **sides and above** the appliance can be reduced. However, it is recommended that the specified clearances are maintained irrespective of the materials used in the construction of the opening to allow adequate air flow and access to controls. **The clearance at the rear of the appliance must always be a minimum of 50mm.**

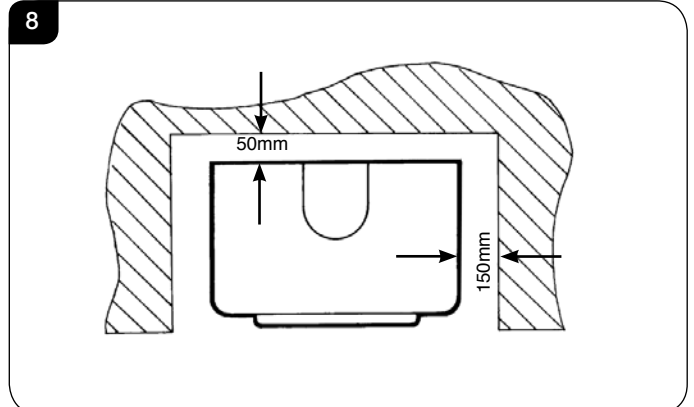
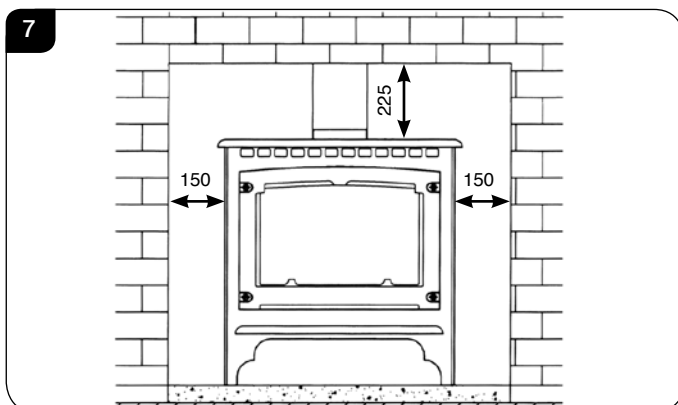

- 7.4 In a non-combustible recess be careful to allow enough clearance at the sides and rear of the appliance to perform spillage tests and reach the controls.

# Installation Instructions

## 1. Safety Precautions

- 1.1 For your own and other's safety, you must install this appliance according to local and national codes of practice. Failure to install the appliance correctly could lead to prosecution. **Read these instructions before installing and using this appliance.**
- 1.2 These instructions must be left intact with the user.
- 1.3 Do not attempt to burn rubbish on this appliance.
- 1.4 Keep all plastic bags away from young children.
- 1.5 Do not place any object on or near to the appliance and allow adequate clearance above the appliance.

**IF THE APPLIANCE IS EXTINGUISHED OR GOES OUT IN USE, WAIT 3 MINUTES BEFORE ATTEMPTING TO RELIGHT THE APPLIANCE.**

**i** **IMPORTANT: REFER TO DATA BADGE AND TECHNICAL SPECIFICATION AT THE FRONT OF THE MANUAL TO ENSURE THE APPLIANCE IS CORRECTLY ADJUSTED FOR THE GAS TYPE AND CATEGORY APPLICABLE IN THE COUNTRY OF USE.**

**FOR DETAILS OF CHANGING BETWEEN GAS TYPES REFER TO SERVICING, SECTION 12, REPLACING PARTS.**

## Unpacking

- 1.6 Remove the appliance from its packaging, and check that it is complete and undamaged.

## 2. Upgrading the Appliance

- 2.1 The appliance is fitted with a control valve that can easily be upgraded to battery powered remote control. There are two versions of this control which can be obtained through your local Gazco retailer. There is no requirement for this upgrade to be carried out by an approved GasSafe engineer. However Gazco recommend that this task is undertaken by a suitably competent person.
- 2.2 This upgrade can be fitted before or after installation but if side clearances are limited then it will be easier to upgrade the appliance before installation. Full instructions are included with the kit.

**i** **If the appliance is left unattended for long periods of time (e.g. vacation), it is recommended to place the control valve in the Off or Pilot position.**

**Take care when leaving the appliance unattended, in exceptional circumstances sound waves from sources other than the transmitter can cause changes in the flame height adjustment.**

**DO NOT install two or more appliances using upgradeable controls in the same room, interference between the remote control frequencies can occur.**

## Standard Remote Control (PART NUMBER 8455)

- 2.3 This remote control can control the gas appliance after the pilot has been lit. It can turn the main burner on and regulate it from low through to high and back again. It can turn the main burner off leaving the pilot burning.

## Thermostatic and Timer Remote Control (PART NUMBER 8456)

- 2.4 This remote control can control the gas appliance after the pilot has been lit.

### MANUAL MODE

Can be used to turn the main burner on and manually regulate it from low through to high and back again. It can also be used to turn the main burner off leaving the pilot burning.

### AUTO MODE

Will automatically regulate the room to a pre-set temperature.

### TIMER MODE

Will turn the appliance on and off according to a pre-set programme and automatically regulate the room temperature during the two on periods.

## 3. Installation of the Appliance



**IMPORTANT: THE OUTER PANNELLING AND DOOR OF THE APPLIANCE IS MADE FROM CAST IRON OR STEEL. TAKE CARE WHEN INSTALLING, REMOVING AND STORING TO AVOID DAMAGING THE OUTER CASING, HEARTH OR DOOR.**

- 3.1 The ceramic logs are located behind the door.
- 3.2 Lift the front upwards until it is clear of the slots and pull away from the appliance, see Diagram 1.

1

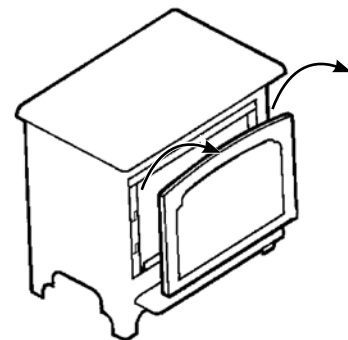

# Installation Instructions

- 3.3 Remove the glass frame by undoing the fixing screws and lifting clear, see Diagram 2. **Take care to support the glass window panel when removing the screws.**

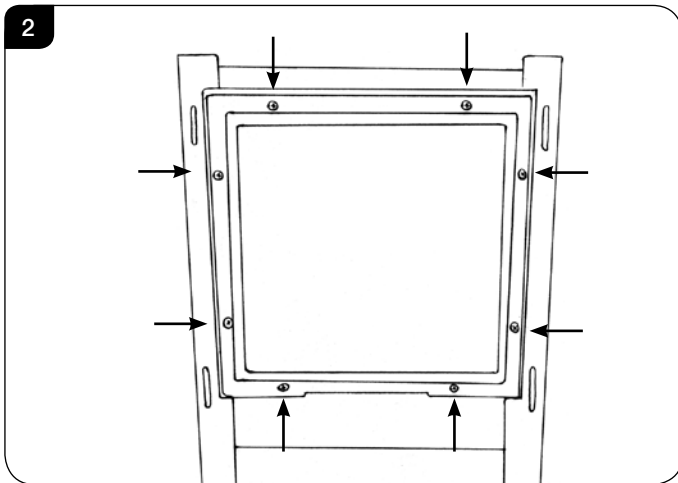

- 3.4 Place carefully to one side.

Remove the box and place in a safe location.

**REFER TO SITE REQUIREMENTS SECTION FOR ALL FLUE OPTIONS.**

The appliance is suitable for TOP or REAR flue exit. If a rear flue has been purchased proceed to 3A. If a top exit is required, proceed to 3B/3C.

## 3A. Rear Exit - Horizontal flue

- 3.5 **Wall thickness:** MIN = 200mm  
MAX = 600mm
- 3.6 Unpack the adjustable flue assembly and terminal guard.
- 3.7 Do not lose the fixings.
- 3.8 Consider the final appliance position ensuring you comply with clearances required for the external flue, see Site Requirements, Section 1.
- 3.9 Mark the vertical centre-line of the appliance on the wall, see Diagram 3.
- 3.10 Mark the height from the top of the hearth to the centre of the flue, see Diagram 3, B.

**TAKE CARE TO MARK OUT THE FLUE CORRECTLY. IT IS DIFFICULT TO MOVE AFTER INSTALLATION.**

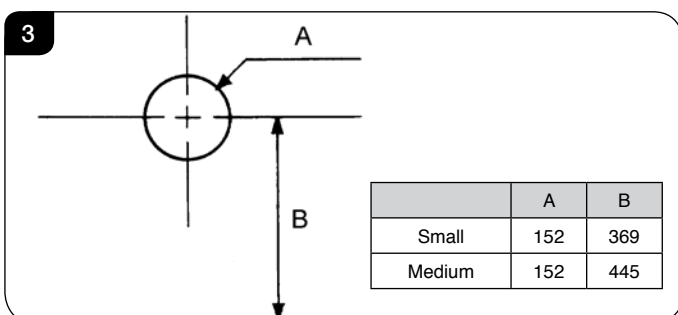

## Flue Aperture

- 3.11 Create a 152mm (6") diameter hole for the flue using either:
- a core drill, or
  - a hammer and chisel

It is advisable to drill small holes around the circumference when using method b).

- 3.12 Make good at both ends of the hole.

## Flue Length

- 3.13 Measure the total wall thickness and add 65mm.
- 3.14 The total flue length gives a minimum clearance of 50mm between the rear of the appliance and the wall.
- 3.15 Insert the square cardboard sleeve into the flue to support the inner tube.
- 3.16 Cut through the flue and sleeve, see Diagram 4.

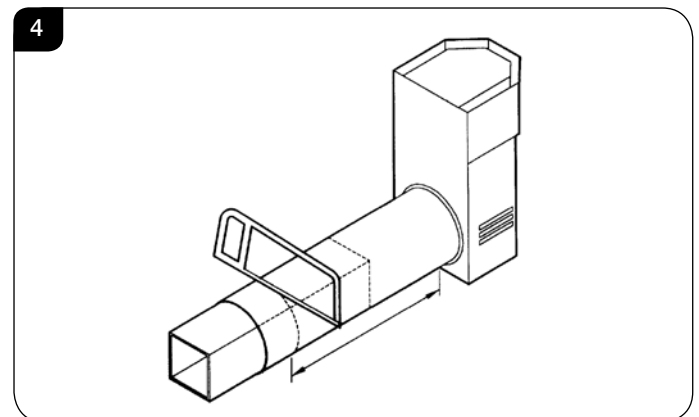

- 3.17 **REMOVE THE CARDBOARD REMNANTS FROM THE FLUE.**

- 3.18 File the cut edges smooth.

## Terminal

On the outside wall:

- 3.19 Position the flue assembly into the hole. The terminal should be flat against the wall.
- 3.20 Make sure the terminal is vertical, see Diagram 5.

**NOTE THE ORIENTATION OF THE TERMINAL, see Diagram 5.**

- 3.21 Mark the 4 fixing holes.
- 3.22 Remove the terminal to drill the holes.
- 3.23 Insert wall plugs supplied.

**DO NOT FIX THE FLUE AT THIS STAGE.**

## Flue and Appliance Fixings

- 3.24 Position the appliance observing appropriate clearances.

# Installation Instructions

- 3.25 Apply a bead of suitable weatherproof sealant (silicone or similar) to perimeter of back face of terminal, see Diagram 5.

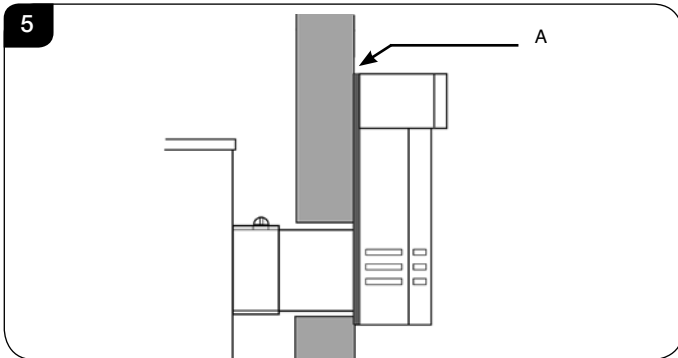

- 3.26 Feed the flue through the wall, making sure it runs smoothly.
- On the inside wall:
- 3.27 Engage the flue in the inner and outer spigots.
- 3.28 Make sure rubber seals on the spigots are not damaged
- From outside:
- 3.29 Insert four screws in the flanges of the flue terminal.
- 3.30 Check sealant has formed a water-tight joint to the wall.
- 3.31 Any terminal less than 2m above any access (level ground, balcony or flat roof with access) must be fitted with the guard supplied, see Diagram 6.

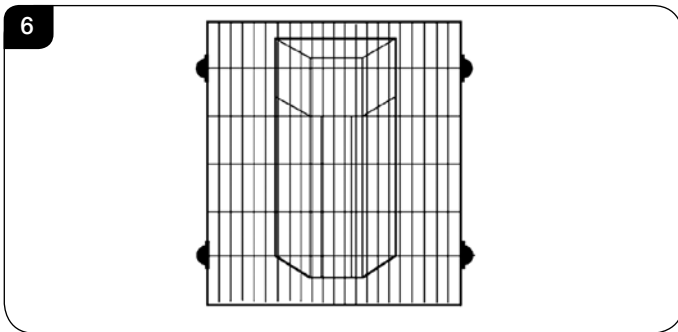

## 3B. Top Exit - Up & Out (Medium Only)

- 3.32 There are two types of top exit flue terminals: vertical and horizontal, (see Site Requirements, Diagram 3, for minimum and maximum flue lengths).

### Decorative Cover

- 3.33 There is an optional decorative collar, Part No: 8548, to cover the gap between the top plate and flue.

**THIS MUST BE POSITIONED BEFORE INSTALLING THE FLUE.**

**i** WHEN INSTALLING A TOP EXIT FLUE, REFER TO INSTALLATION INSTRUCTIONS, TECHNICAL SPECIFICATION (PAGE 12) FOR THE APPROPRIATE SIZE RESTRICTOR.

### Reversing Spigots

- 3.34 The appliance is factory set for rear exit. For top exit reverse the spigots and blanking plates, see Diagram 7.

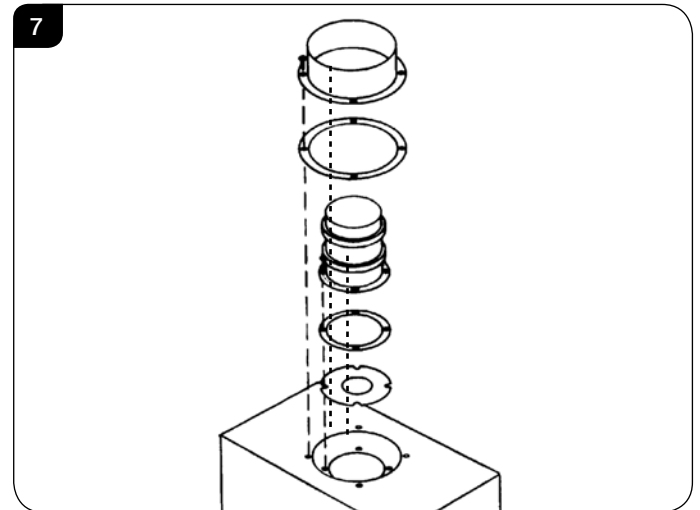

- 3.35 **REMEMBER TO FIT THE OPTIONAL DECORATIVE COLLAR IF REQUIRED.**

### Wall Plate

- 3.36 A wall plate is supplied to secure the flue to the inside wall. Bend the securing tab to 90° and slot the plate over the flue before bringing the flue through the wall.
- 3.37 Mark the fixing holes using the wall plate as a template. The tab can be above or beneath the flue, see Diagram 8.

### Flue Aperture

- 3.38 Mark the height from the top of the hearth to the centre of the horizontal section, see Diagram 8.

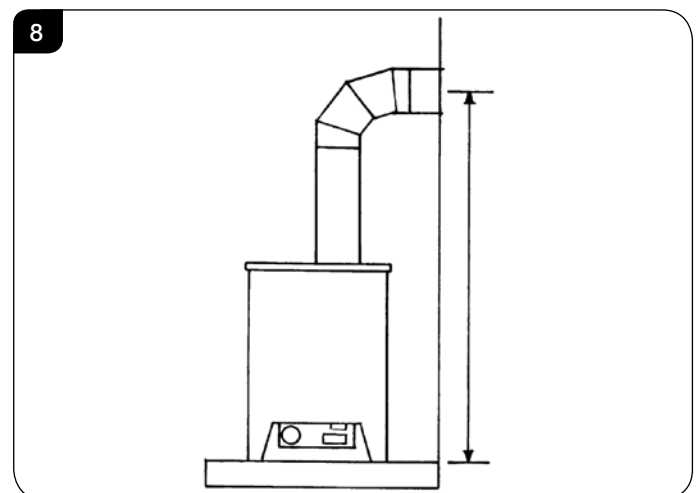

- 3.39 **TAKE CARE TO MARK OUT THE FLUE CORRECTLY. IT IS DIFFICULT TO MOVE AFTER INSTALLATION.**

# Installation Instructions

- 3.40 Create a 152mm (6") diameter hole for the flue using either:  
a) a core drill, or  
b) a hammer and chisel

3.41 Make good at both ends of the hole.

## Flue Length

3.42 The final length of the flue pipe includes the terminal. The terminal is the only section that can be shortened.

**DO NOT SHORTEN ANY OTHER SECTION OF FLUE PIPE.**

3.43 Measure from the outside of the wall to the stop on the 90° elbow.

3.44 Fit horizontal flue section between the elbow and the terminal at this stage, if required, see Diagram 9.

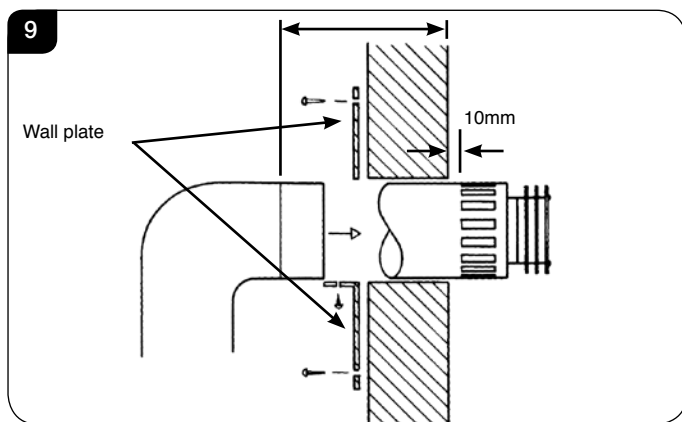

3.45 Mark the correct length all the way around the flue terminal section, see Diagram 10.

3.46 Insert the square cardboard sleeve into the flue to support the inner tube.

3.47 Cut through the flue and sleeve, see Diagram 10.

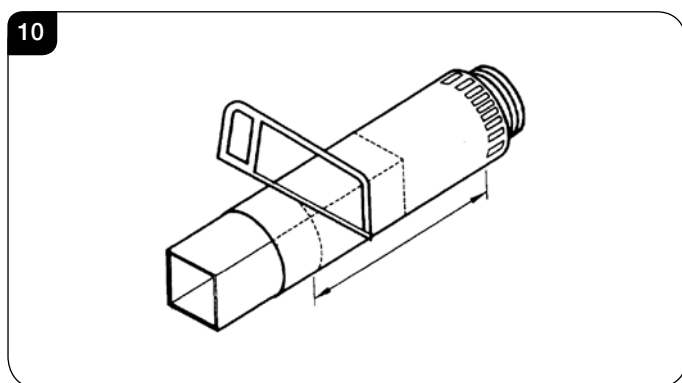

3.48 **REMOVE THE CARDBOARD REMNANTS FROM THE FLUE.**

3.49 File the cut edge smooth.

## Flue and Appliance Fixings

3.50 Pull appliance and flue assembly away from the hearth.

3.51 Drill four fixing holes for the wall plate and insert wall plugs supplied.

3.52 Put the horizontal flue onto the elbow and reposition the appliance.

3.53 Check the flue runs smoothly through the wall.

3.54 Fix the wall plate to the wall using the four black screws provided.

3.55 Drill through the fixing tab of the wall plate using a 3.5mm drill.

3.56 Secure with the screw provided.

3.57 Make good and weatherproof around the outside of the flue.

## 3C. Top Exit – Vertical Flue

3.58 Where a vertical only flue system has been purchased, refer to Installation & Instructions, Site Requirements, Section 4D.

3.59 Pay careful attention to the following:

- Terminal positions
- Flue supports
- Weatherproofing
- Fire precautions

3.60 Local and national codes of practice must be followed for all the above.

## TOP EXIT – VERTICAL ONLY, INCLUDING OFFSET



**A RESTRICTOR MUST BE FITTED WITH VERTICAL FLUES. REFER TO INSTALLATION INSTRUCTIONS, TECHNICAL SPECIFICATION (PAGE 12) FOR THE APPROPRIATE SIZE RESTRICTOR.**

**PLEASE NOTE: When installing the appliance in conjunction with a vertical termination kit, there is a unique kit for use with this appliance (Part No. 8530).**

## 4. Gas Soundness Pressure Check

4.1 Connect a suitable pressure gauge to the test point located on the inlet fitting and turn the gas supply on. Light the appliance and check all gas joints for possible leaks. Turn the appliance to maximum and check that the supply pressure is as stated on the databadge. Turn the gas off and replace the test point screw, turn the gas on and check the test point for leaks.

# Installation Instructions

## 5. Arrangement of Fuel Bed

### Advice on handling and disposal of fire ceramics



The fuel effect and side panels in this appliance are made from Refractory Ceramic Fibre (RCF), a material which is commonly used for this application.

Protective clothing is not required when handling these articles, but we recommend you follow normal hygiene rules of not smoking, eating or drinking in the work area and always wash your hands before eating or drinking.

To ensure that the release of RCF fibres are kept to a minimum, during installation and servicing a HEPA filtered vacuum is recommended to remove any dust accumulated in and around the appliance before and after working on it. When servicing the appliance it is recommended that the replaced items are not broken up, but are sealed within heavy duty polythene bags and labelled as RCF waste.

RCF waste is classed as stable, non-reactive hazardous waste and may be disposed of at a licensed landfill site.

Excessive exposure to these materials may cause temporary irritation to eyes, skin and respiratory tract; wash hands thoroughly after handling the material.

## 6. Log Layout

### Small Marlborough2

All logs can be identified by a letter (A - E) on their underside. Logs B and E also have holes to locate each onto a burner stud.

- 6.1 Ensure the burner tray is clean and free from any debris, see Diagram 11.

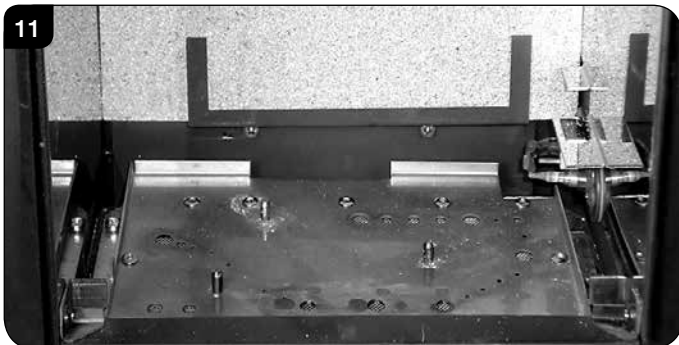

- 6.2 Place Log A on the higher rear bracket and push up against the back panel, see Diagram 12.

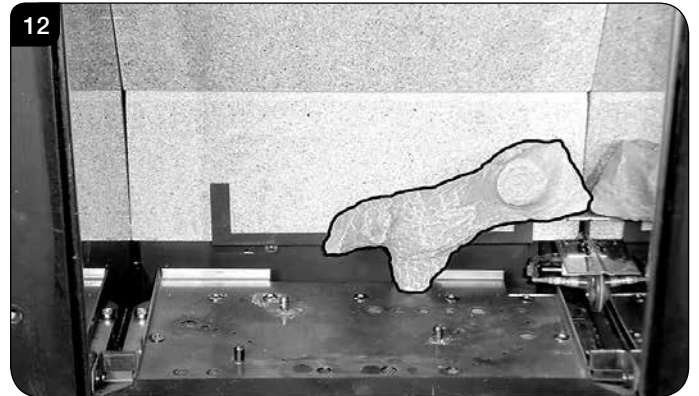

- 6.3 Place Log B over the two middle studs on the burner tray, see Diagram 13.

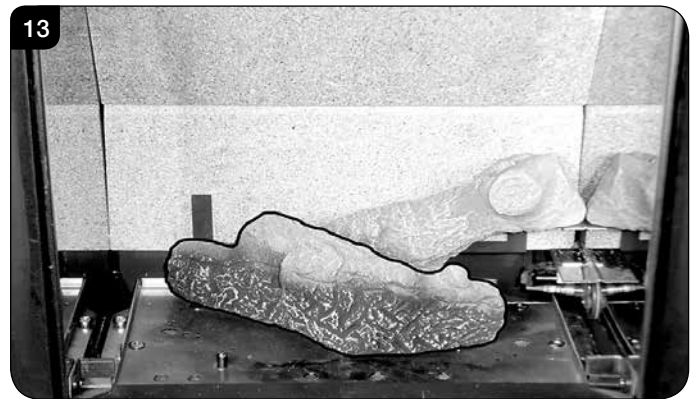

- 6.4 Place Log E onto the stud and behind the tag on the left hand side of the burner tray. Rest against Log B, see Diagram 14.

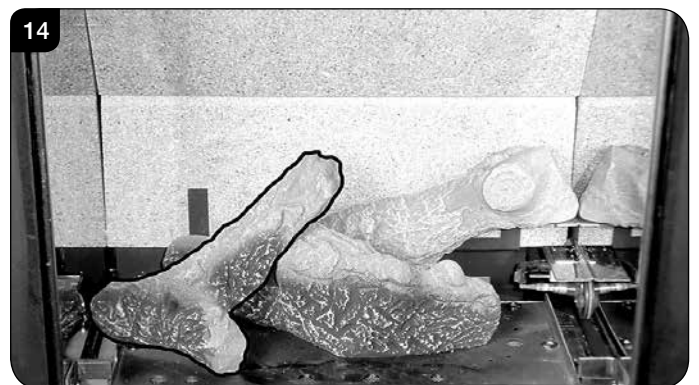

# Installation Instructions

- 6.5 Place the small Ember at the front left of the firebox, against the rear of the log support bracket to obscure the reflection of the burner screw.

Place the larger Ember on the lower bracket above the pilot on the right hand side with the thicker edge facing the front and flat edges to the base and side, see Diagram 15.



- 6.6 Log C rests on the cutout on Log E and is pushed up to the side and rear of the firebox, see Diagram 16.

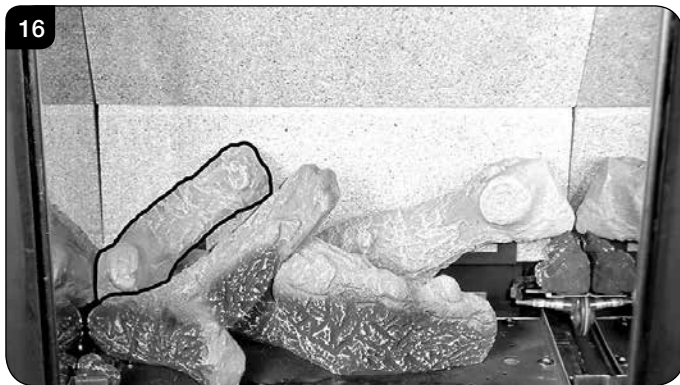

- 6.7 Place the pointed bottom of log D into the corner of the burner tray and rest on the location stud on log B see Diagram 17.

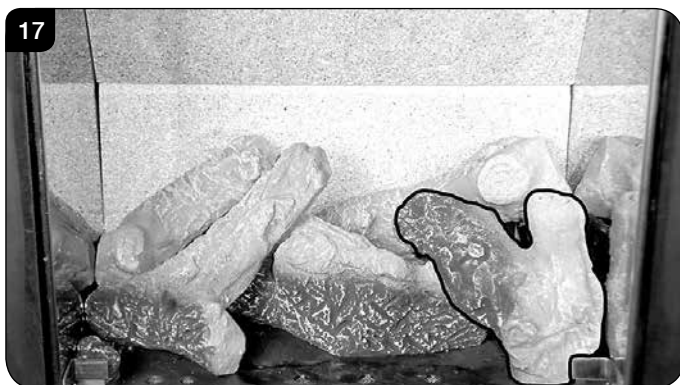

- 6.8 Sparingly spread an amount of the Embaglow fibres provided, covering the ports in the burner tray. Use a small piece in front of the log on the left hand side and a long strip in front of log B, see Diagram 18.

Take care not to use more than half a packet per application.

**WARNING - DO NOT PLACE NEAR THE PILOT AREA.**

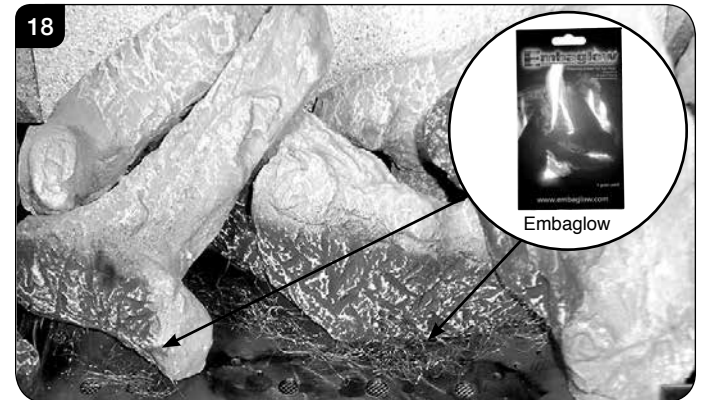

- 6.9 Lower log guard into position, see Diagram 19.



## Medium Marlborough2

- 6.10 The logs for the fuel bed are clearly individually labelled, A to D.
- 6.11 Ensure the burner tray is clean and free from any debris, see Diagram 20.

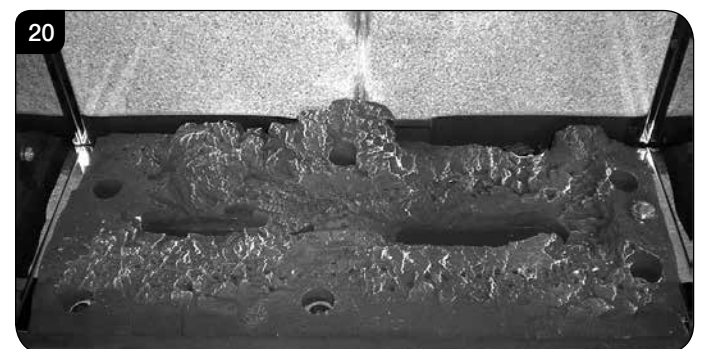

# Installation Instructions

- 6.12 There are 3 embers. Place 2 embers in the back corners of the burner, resting in the cut outs, see Diagram 21. Place the last ember loosely at the front of the fuel bed to cover the hole in the centre.

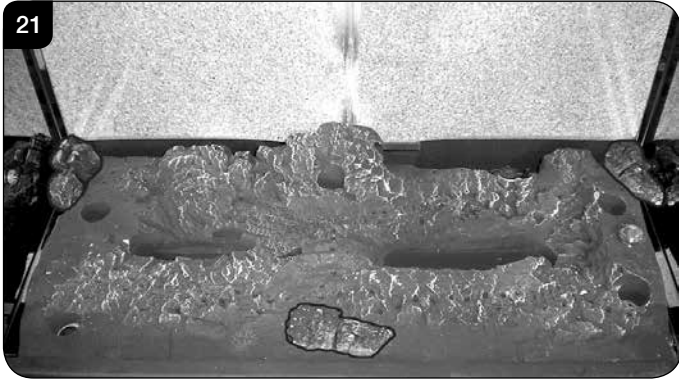

- 6.13 Place Log D on the left hand side of the burner. There is a hole on the underside of Log D which fits over the raised stud on the left of the burner. The back of the log should rest flat against the back panel, see Diagram 22.

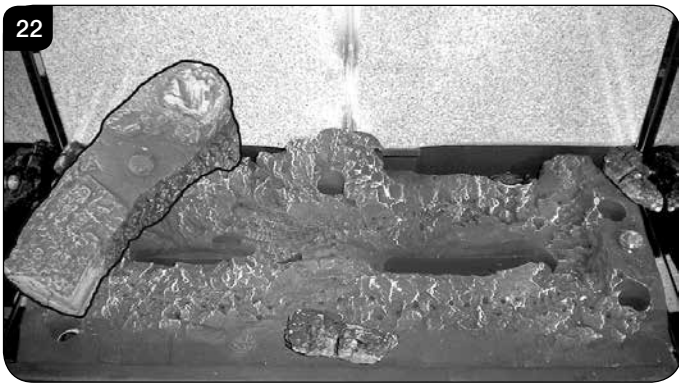

- 6.14 Place Log B on top of Log D. There is a hole on the underside of Log B which fits over the raised stud on Log D to secure in place. The right hand side of the log rests in the groove in the burner, see Diagram 23.

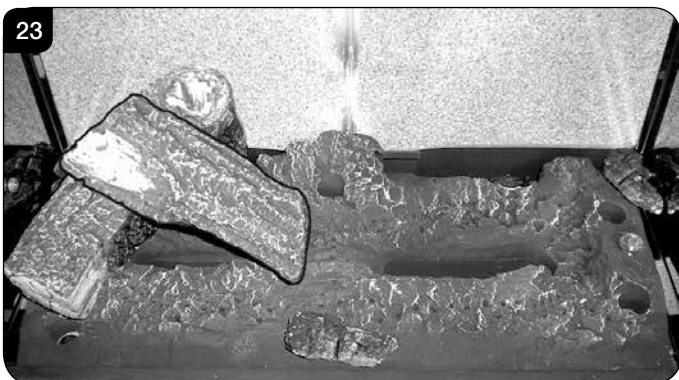

- 6.15 Place Log C on the right hand side of the burner. There is a hole on the underside of Log C which fits over the raised stud on the right of the burner. The back of the log should rest flush against the back panel, see Diagram 24.



- 6.16 Place the log guard into position on the grooves on the sides of the firebox, see Diagram 25.



- 6.17 Place Log A across Log C. There is a hole on the underside of Log A which fits over the raised stud on Log C to secure in place. The small cut out on the left side of the log rests onto the log guard, see Diagram 26.





# Installation Instructions

- 6.18 Once the logs are in place sparingly spread an amount of the Embaglow fibres provided on the sections highlighted, see Diagram 27.

Take care not to use more than half a packet per application.

**WARNING - DO NOT PLACE NEAR THE PILOT AREA.**

**IT IS ESSENTIAL TO KEEP THE REAR PORT FREE FROM OBSTRUCTION.**

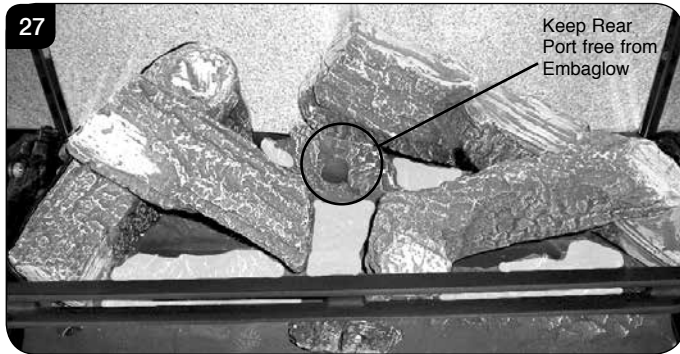

- 6.19 Refit the glass frame by tightening the fixing screws, see Diagram 28. Ensure that the rope seal on the back of the glass frame is intact.

**Take care to support the glass window panel when replacing the screws.**

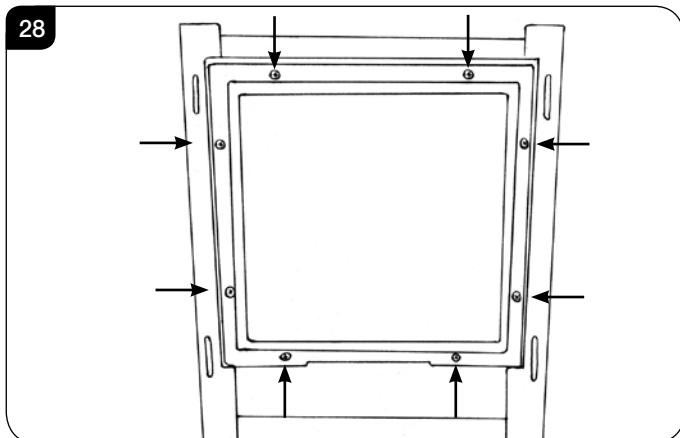

- 6.20 Locate the door on the 4 slots and secure to the firebox, see Diagram 29.

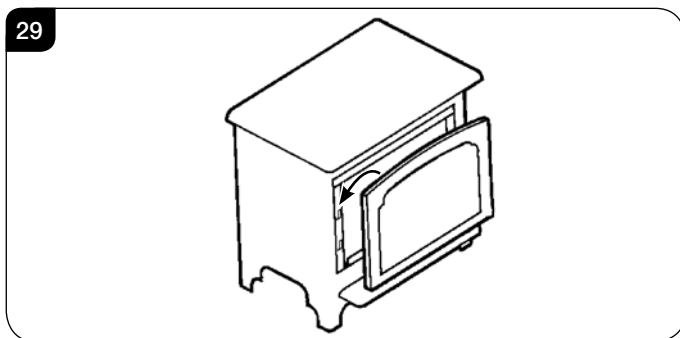

**NEVER OPERATE THE APPLIANCE WHEN THE DOOR IS REMOVED, OR THE GLASS IS BROKEN.**

**! UNDER NO CIRCUMSTANCES SHOULD THE APPLIANCE BE USED IF ANY OF THE GLASS FRAME RETAINING SCREWS ARE LOOSE OR MISSING.**

## 7. Operating the Appliance

- 7.1 Locate the control valve on the appliance. It has two controls, see Diagram 30.

1. The right-hand knob controls the pilot ignition.
2. The left-hand knob controls the main burner.

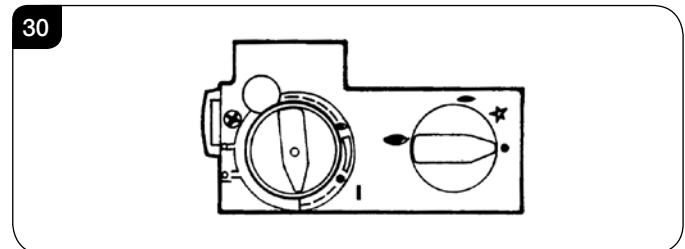

- 7.2 Refer to separate instructions if your appliance is upgraded to include battery remote control. The instructions below apply whether or not you have the remote upgrade.

### Lighting the Pilot

- 7.3 To start the left-hand and right-hand control knobs must both point to off (●):

- 7.4 Press in the right-hand control knob and rotate anti-clockwise until a click is heard. Continue to press in. The knob points to the pilot (←).

The pilot is lit.

- 7.5 Keep the knob depressed for 10 seconds before releasing. The pilot remains lit.

Repeat the above steps if the pilot does not stay lit.

**NOTE: If the pilot goes out, the Interlock system prevents you lighting again for a short period.**

- 7.6 If, after repeating the above steps the pilot does not light, contact your Retailer or Installer.

- 7.7 Turn the right-hand knob to the left to main burner setting (↔).

### Adjusting the Flame height

- 7.8 You can now adjust the flame height and temperature using the left-hand control knob.

- 7.9 Turn the left-hand knob anti-clockwise to increase the flame height.

- 7.10 Turn clockwise to decrease the height.

**i IMPORTANT: YELLOW FLAMES TYPICALLY APPEAR WHEN THE APPLIANCE HAS REACHED NORMAL OPERATING TEMPERATURE. THIS CAN TAKE UP TO 30 MINUTES.**

**! WARNING: IF THE APPLIANCE FAILS TO LIGHT OR BECOMES EXTINGUISHED IN USE, WAIT 3 MINUTES BEFORE ATTEMPTING TO RELIGHT.**

# Commissioning

## 1. Commissioning

- 1.1 Complete the Commissioning Checklist at the front of this manual covering:
  - Thermocouple soundness checks.  
This is to include ensuring the thermocouple is secure on the pilot bracket assembly, lead connection and integrity.
  - Flue checks
  - Gas checks
  - Log layout - flame picture
- 1.2 Ensure all safety checks listed in the Commissioning Section are completed, paying particular attention to the glass panel checks and securing of the door.
- 1.3 Upon completion of the commissioning and testing of the installation and correct operation of the appliance, the installer must instruct the user how to operate the appliance.
- 1.4 Guide the user through the User Instructions paying particular attention to:
  - a) Regular servicing (Section 10 of the User Instructions).
  - b) Ventilation (Section 11 of the User Instructions) - point out the ventilation positions where applicable.
  - c) Hot surfaces (Section 13 of the User Instructions).

# Servicing Instructions

## Servicing/Fault Finding Charts

### 1. Servicing Requirements

**IMPORTANT – The glass panel on this appliance should be checked for any signs of damage on the front face of the glass panel (scratches, scores, cracks or other surface defects). If damage is observed, the glass panel must be replaced and the appliance must not be used until a replacement is installed. Under no circumstances should the appliance be used if any damage is observed. Please isolate the appliance until a replacement glass panel has been obtained and installed. Replacement glass panels can be purchased from Gazco via the retailer from which the appliance was purchased or any other Gazco distributor.**

This appliance must be serviced at least once a year by a competent person.

All tests must be carried out in accordance with the current GasSafe recommendations.

#### 1.1 Before Testing:

- Conduct a gas soundness test for the property ensuring there are no leaks before servicing.
- Check the operation of the appliance before testing.

#### 1.2 Special checks:

- Clean the burner using a vacuum cleaner with a soft brush attachment. Ensure all debris is removed from the burner ports.

- Clean any lint or fluff from the pilot - pay particular attention to the aeration holes of the pilot
- Clean away lint or fluff from under the burner.
- Check the spark gap on the pilot is correct, see Diagram 1.
- Check all of the screws which secure the burner skins and tighten if they are loose.
- Ensure that the door is secured correctly and that all retaining nuts are in place.

1.3 Correct any faults found during the initial test.

1.4 Re-commission the appliance in accordance with Commissioning Procedures.

1.5 Advise the customer of any remedial work undertaken.

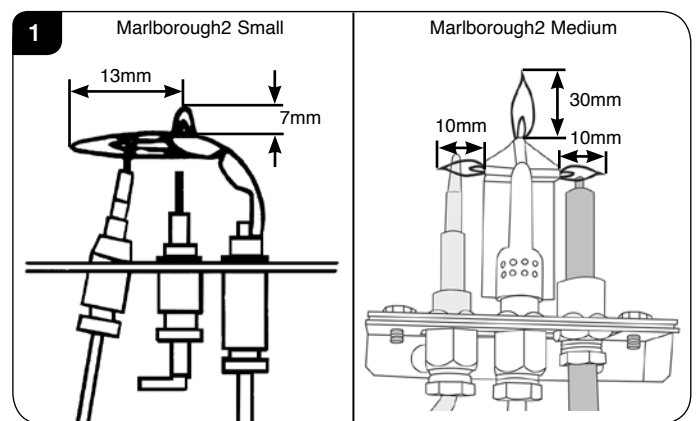

### IGNITION FUNCTIONAL CHECK 1

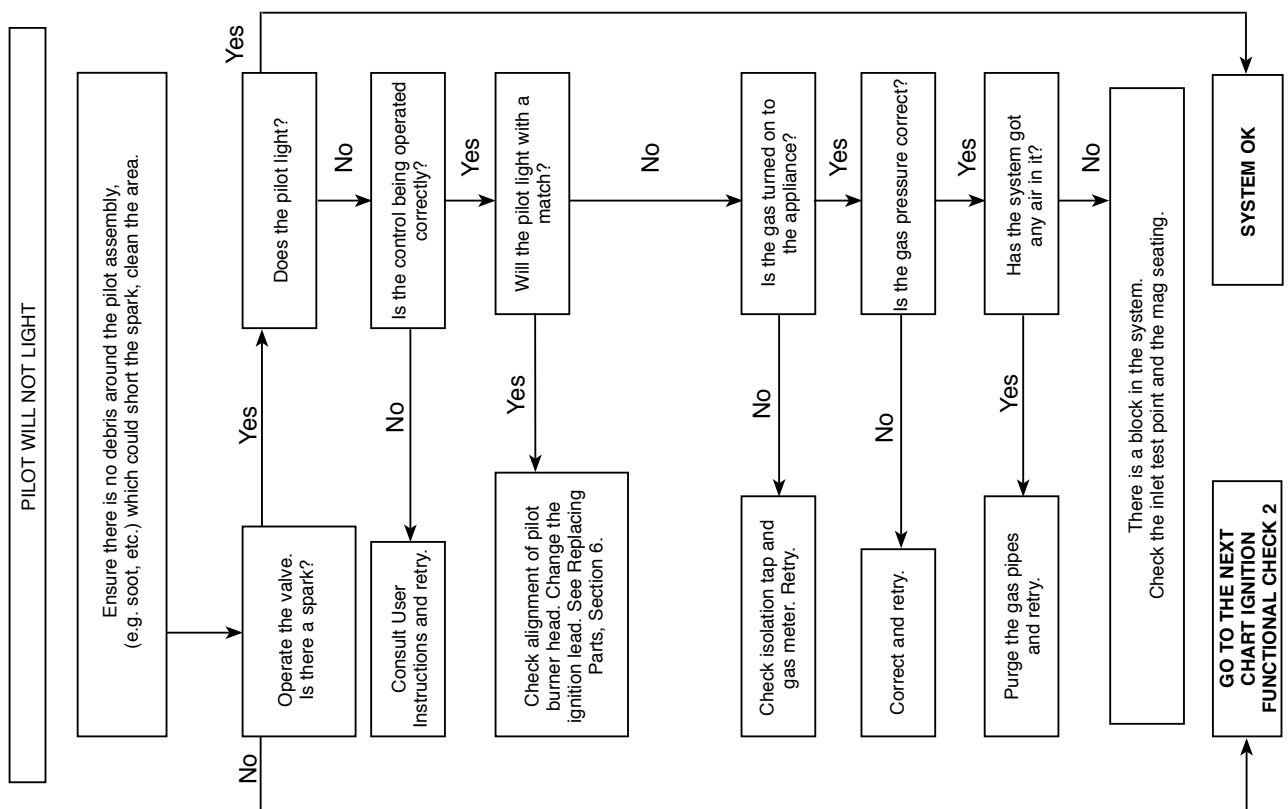

# Servicing Instructions

## Fault Finding Charts

### FLAME FAILURE FUNCTIONAL CHECK 3

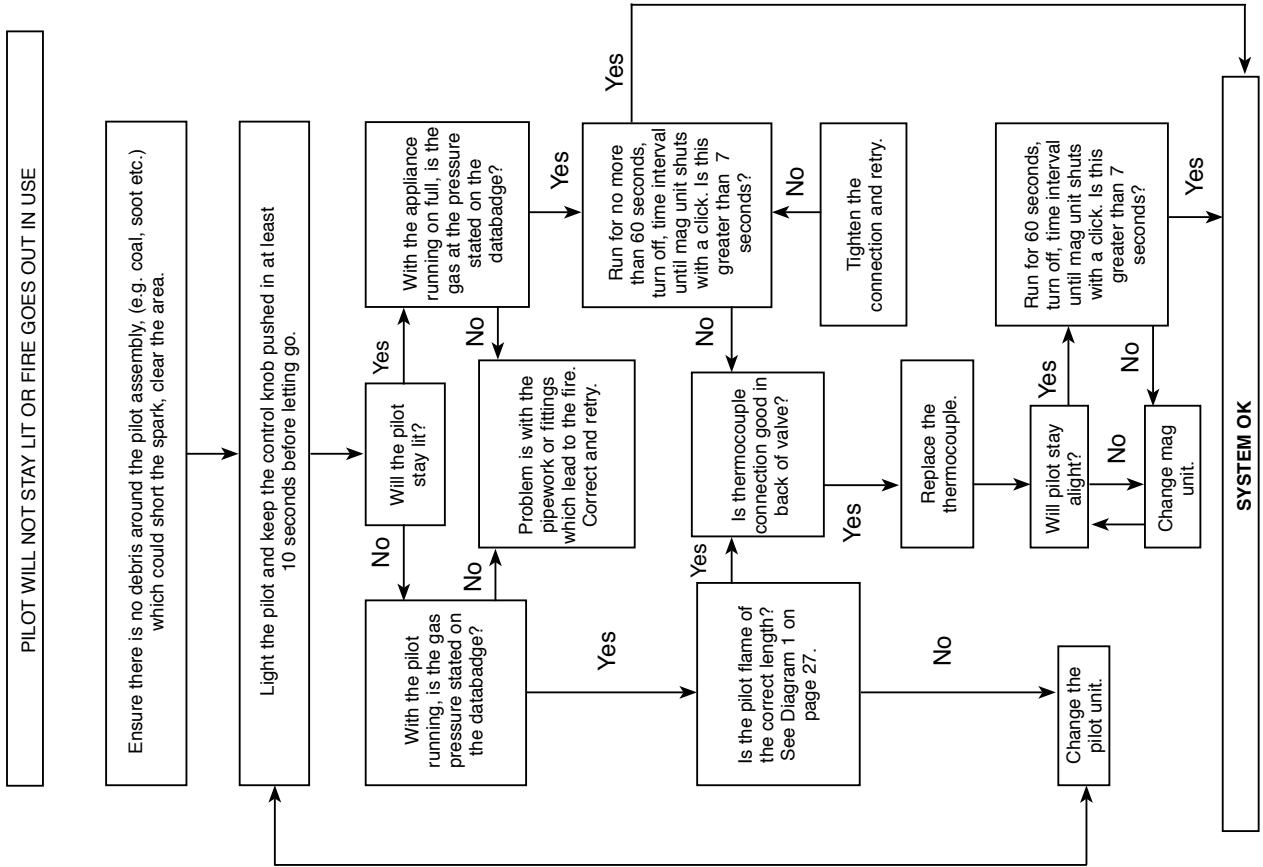

### IGNITION FUNCTIONAL CHECK 2

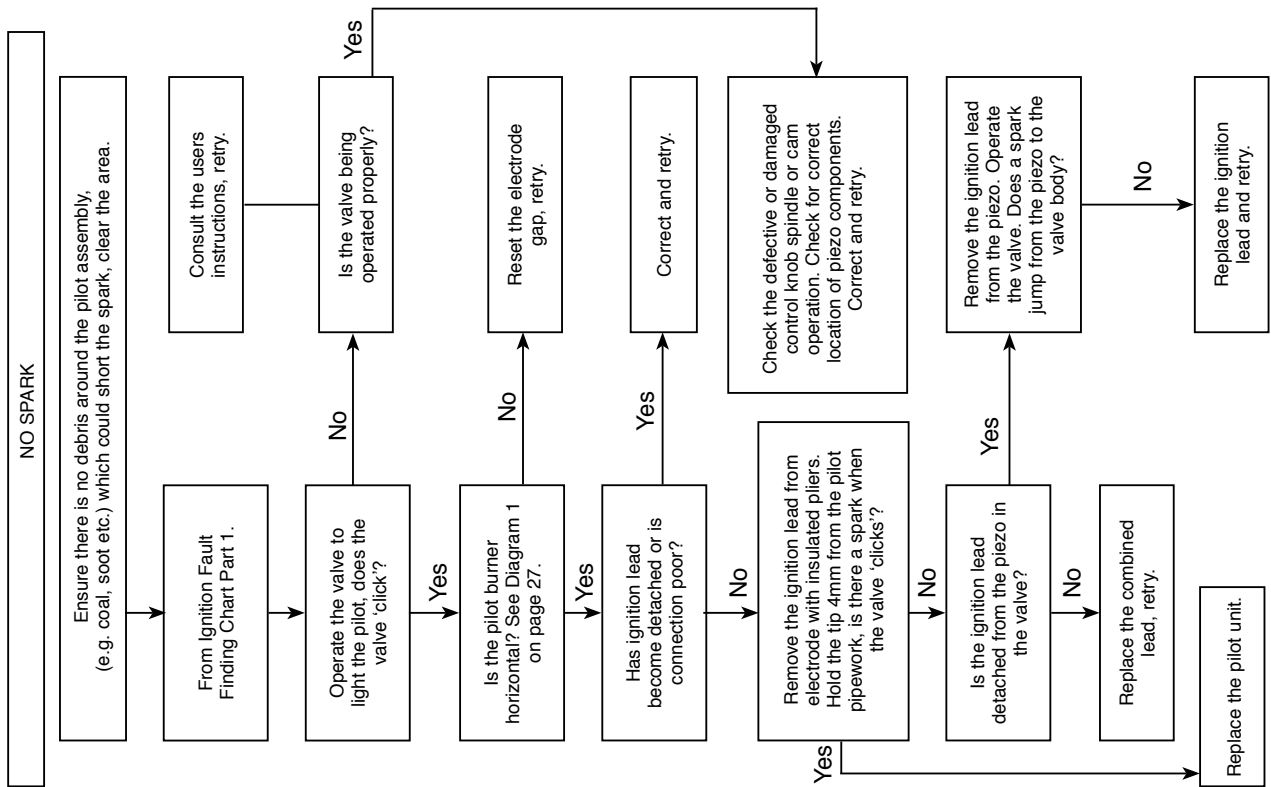

# Servicing Instructions - Replacing Parts

## 1. General

- 1.1 All main components can be replaced without removing the appliance from its installation.
- 1.2 Ensure the appliance and surrounds are cool before servicing.

**IT IS ESSENTIAL THAT THE GAS SUPPLY TO THE APPLIANCE IS TURNED OFF AT THE ISOLATION DEVICE BEFORE PROCEEDING FURTHER.**

- 1.3 If, for any reason, the flue has to be removed from the appliance, the seals must be replaced.

## 2. Removing the Door



**IMPORTANT: THE OUTER PANNELLING AND DOOR OF THE APPLIANCE IS MADE FROM CAST IRON OR STEEL. TAKE CARE WHEN INSTALLING, REMOVING AND STORING TO AVOID DAMAGING THE OUTER CASING, HEARTH OR DOOR.**

- 2.1 Lift the front upwards until it is clear of the slots and pull away from the appliance, see Diagram 1.

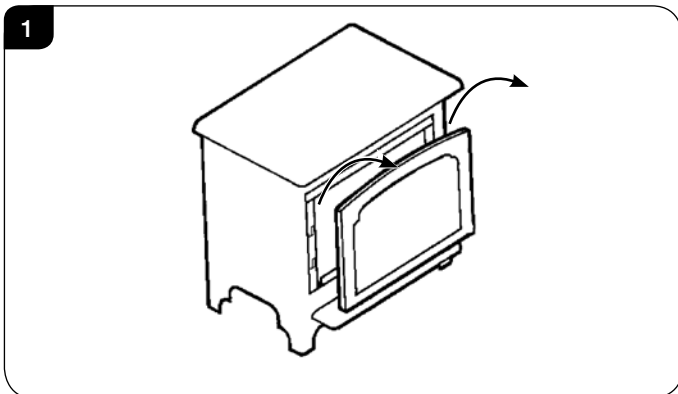

- 2.2 Remove the glass frame by undoing the fixing screws and lifting clear, see Diagram 2. **Take care to support the glass window panel when removing the screws.**

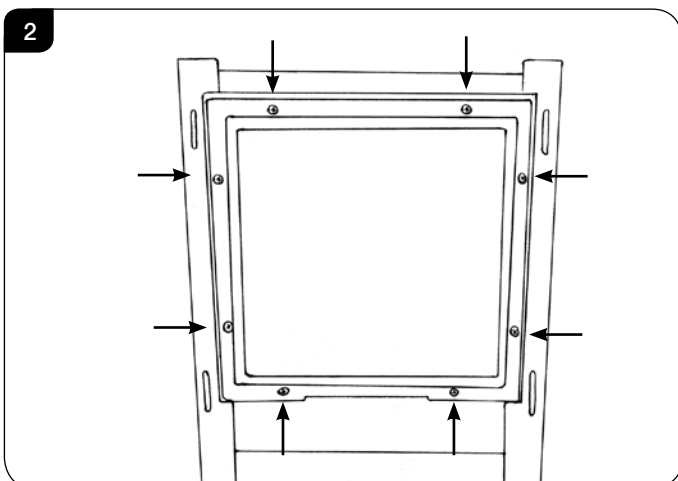

- 2.3 Place carefully to one side.
- 2.4 Lift out the log guard and carefully remove the ceramic fuel bed components.
- 2.5 Refit in reverse order ensuring that the rope seal is intact.
- 2.6 Locate the door on the 4 slots and secure to the firebox.

**NEVER OPERATE THE APPLIANCE WHEN THE DOOR IS REMOVED, OR THE GLASS IS BROKEN.**



**UNDER NO CIRCUMSTANCES SHOULD THE APPLIANCE BE USED IF ANY OF THE GLASS FRAME RETAINING SCREWS ARE LOOSE OR MISSING.**

## 3. Baffle & Ceramic Liners

- 3.1 To access the burner tray and interior workings of the appliance it may be necessary to remove the baffle and the liners.

### 3a. Liners (Marlborough2 Small only)

#### BAFFLE

- 3.2 There is no requirement to remove the baffle for servicing.
- 3.3 The burner can be accessed without the need to remove the side liner panels. If they need to be taken out then first remove the screws securing the two brackets on either side of the firebox. The panels will now slide forward, see Diagram 3.

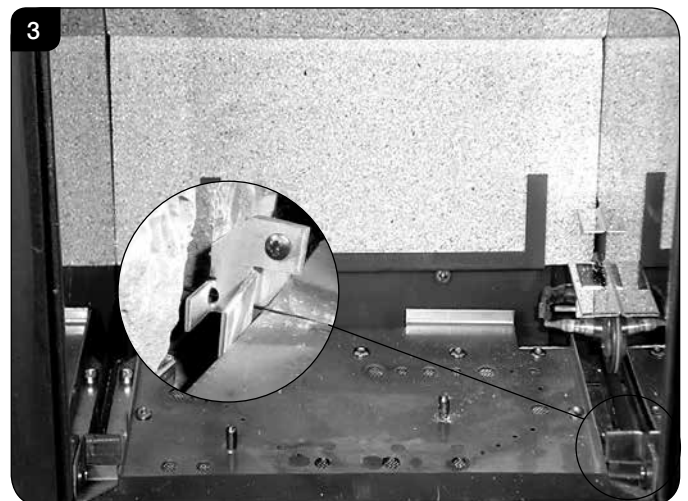

# Servicing Instructions - Replacing Parts

## LINERS

- 3.4 Gently lift the upper rear liner and pull forwards. With the panel raised it should be possible to remove from the liner brackets, see Diagram 4.  
Note: It may be necessary to use a flat object like a screwdriver to separate the two panels.

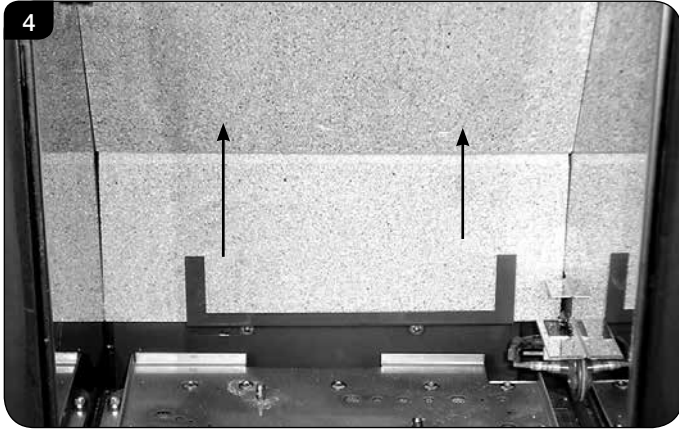

- 3.5 Slide the lower rear liner up and out of the lower bracket, see Diagram 5.

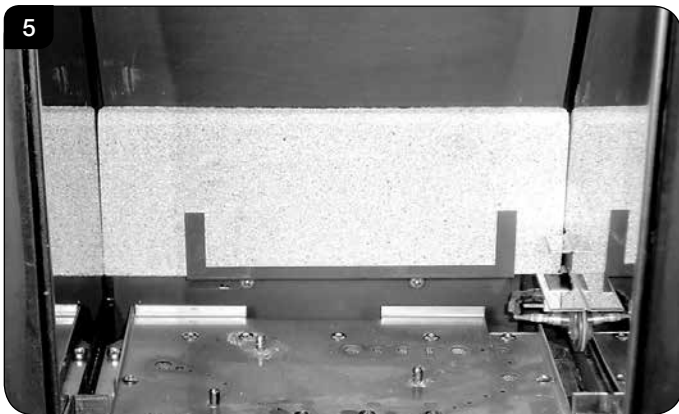

- 3.6 Replace all parts in reverse order ensuring the cutouts in the rear of the lower panel fit over the screws on the back of the firebox, see Diagram 6.

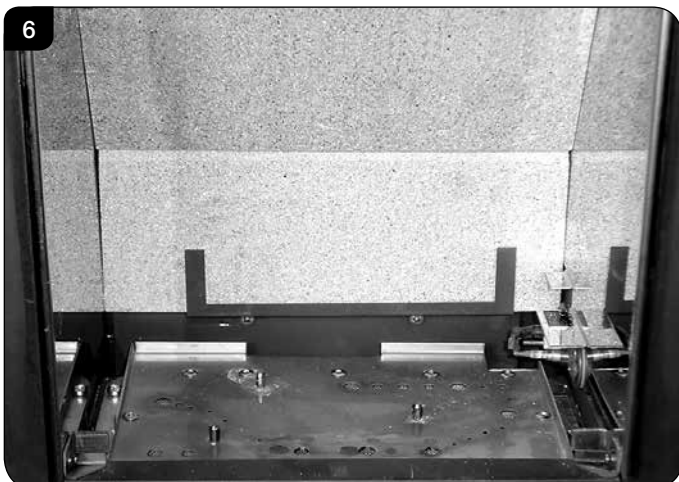

## 3b. Baffle & Liners (Marlborough2 Medium only)

- 3.7 To access the burner tray and interior workings of the appliance it may be necessary to remove the baffles and the liners.
- 3.8 This appliance has 2 baffles, 1 metal and 1 vermiculite, that must be removed before the liners can be taken out of the appliance.
- 3.9 Remove the logs.

### METAL BAFFLE

To remove the metal baffle:

- 3.10 Undo the 3 screws securing it to the roof of the firebox, see Diagram 7.

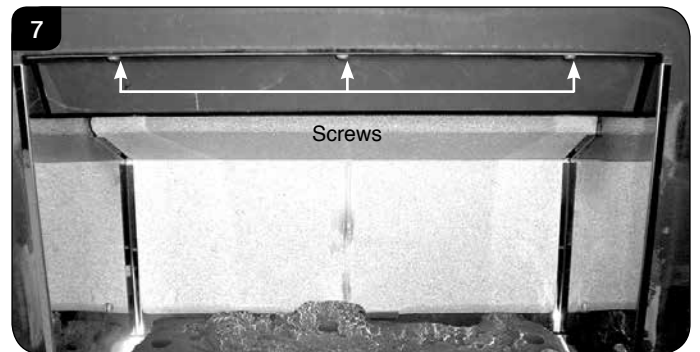

- 3.11 The baffle can now be removed through the front of the appliance.

### VERMICULITE BAFFLE

To remove the vermiculite baffle:

- 3.12 Lift the vermiculite baffle and slide out through the front of the appliance, see Diagram 8.

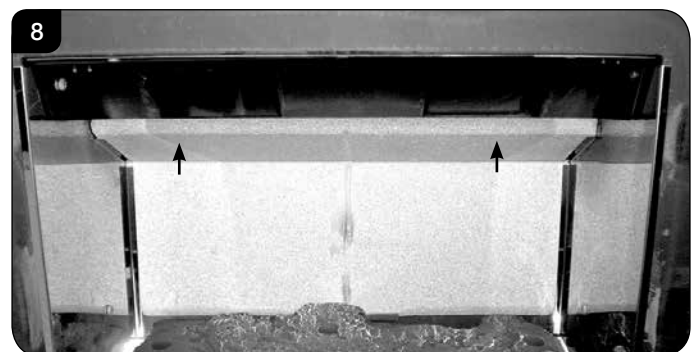

Once the baffles have been placed carefully to one side the liners can then be taken out in the following order.

# Servicing Instructions - Replacing Parts

## REFLECTIVE LINERS

3.13 To remove the left hand liner undo the 3 screws, including the 1 under the log guard bracket, see Diagram 9.

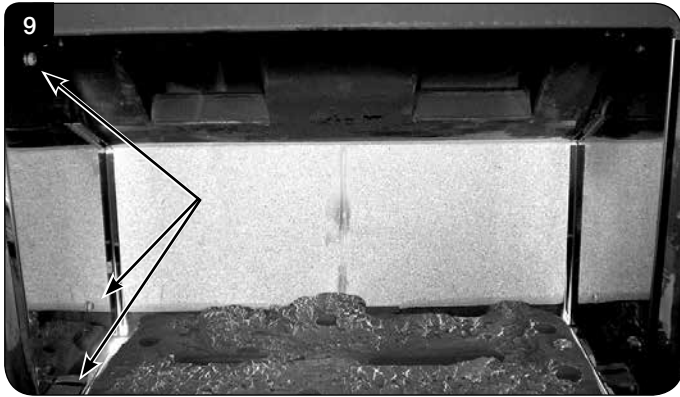

3.14 Remove the log guard bracket.

3.15 Tilt the liner inwards towards the centre of the firebox before lifting up and pulling out through the front of the firebox, see Diagram 10.

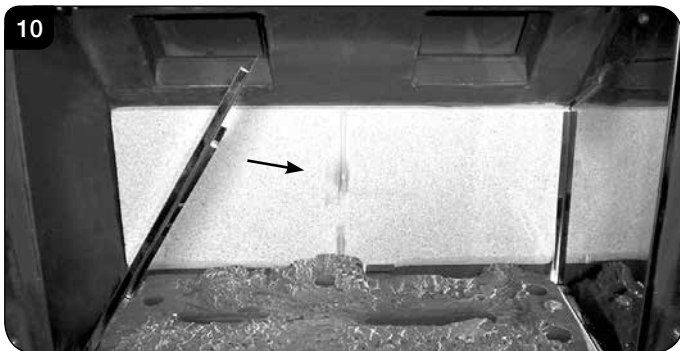

3.16 To remove the right hand liner undo the 3 screws, including the 1 under the log guard bracket, see Diagram 9.

3.17 Remove the log guard bracket.

3.18 Tilt the liner inwards towards the centre of the firebox before lifting up and pulling out through the front of the firebox, see Diagram 10.

## VERMICULITE LINER

3.19 The rear liner does not need to be removed in order to access the burner tray for maintenance, however it is advisable to remove the rear panel to avoid possible damage and to clean or replace.

3.20 To remove the back panel lift out of the bracket and remove through the front of the appliance, see Diagram 11.

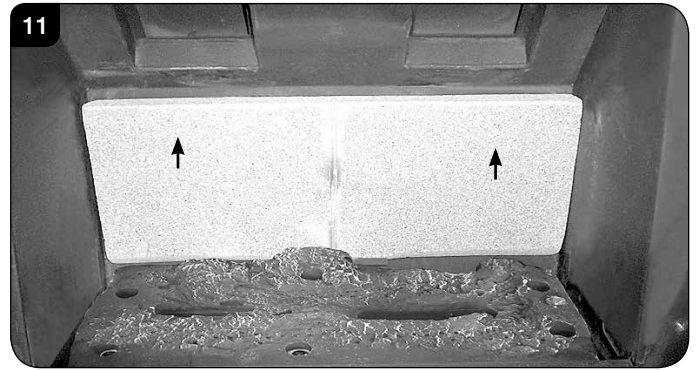

3.21 With the liners and baffle removed the firebox is clear for cleaning and maintenance, see Diagram 12.

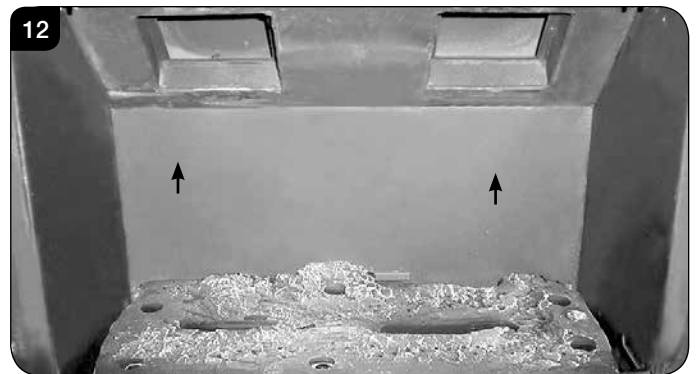

## 4. Main Burner

To replace the main burner:

4.1 Remove the baffle and liners, see Section 3.

4.2 Lift one side of the burner vertically and manoeuvre out of the firebox, see Diagram 13.

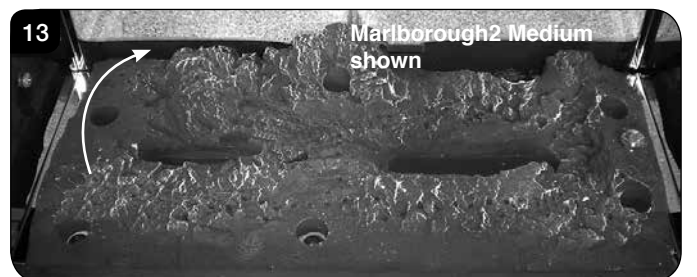

Refit in reverse order.

# Servicing Instructions - Replacing Parts

## 5. Pilot Unit

All models have a serviceable Pilot Unit - see section for individual model requirements.



**IMPORTANT: UNDER THE TERMS OF THE EXTENDED WARRANTY IT WILL BE COMPULSORY TO CHANGE THE COMPLETE PILOT UNIT ON THIS APPLIANCE IN YEARS 2 AND 4.**

## Marlborough2 Small Only

- 5.1 The pilot assembly consists of five components, which can be individually replaced:

Pilot burner bracket  
Pilot injector  
Electrode  
Thermocouple  
Gasket

- 5.2 Turn the gas supply off at the isolation device, remove the door and place to one side, carefully remove the ceramic fuel bed components.

## Pilot Burner Bracket

- 5.3 Remove the two fixing screws from the pilot bracket, see Diagram 14. Gently draw the assemble away from the firebox to give access to the nuts and ignition lead.  
**NOTE: TAKE CARE NOT TO DAMAGE THE GASKET.**

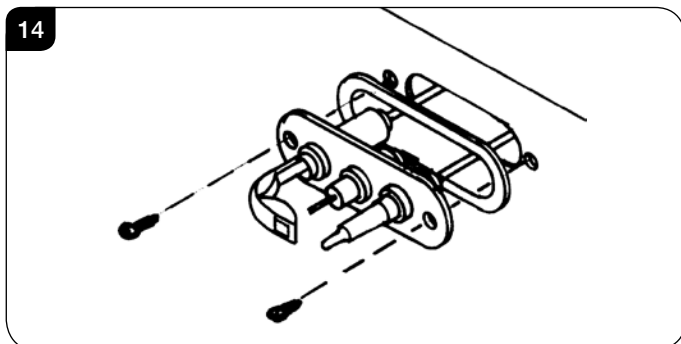

## Pilot Injector

- 5.4 Undo the compression nut on the pilot feed pipe and withdraw the injector which will be hooked onto the olive. When replacing an injector always make sure it is hooked onto the olive before inserting it into the pilot burner, see Diagram 15.

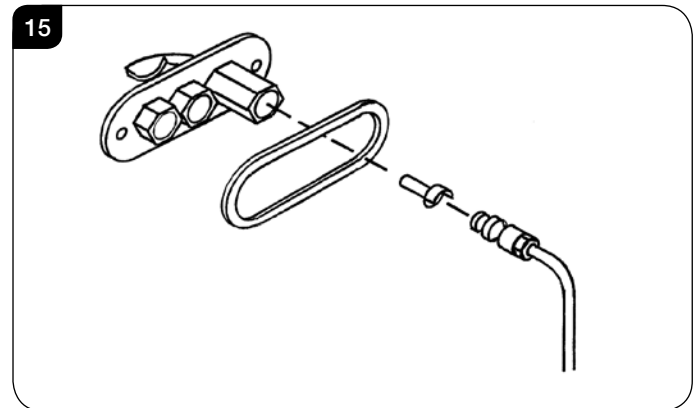

## Electrode

- 5.5 Disconnect the ignition lead and undo the retaining nut. The electrode can now be removed, note the orientation of the electrode terminal when reassembling, see Diagram 16.

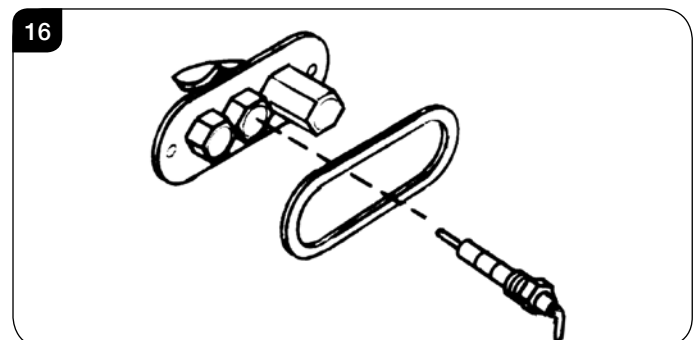

## Thermocouple

- 5.6 Undo the retaining nut and withdraw the thermocouple. Undo the thermocouple from the back of the gas valve, see Diagram 17. Reassemble in reverse order. Do not overtighten.

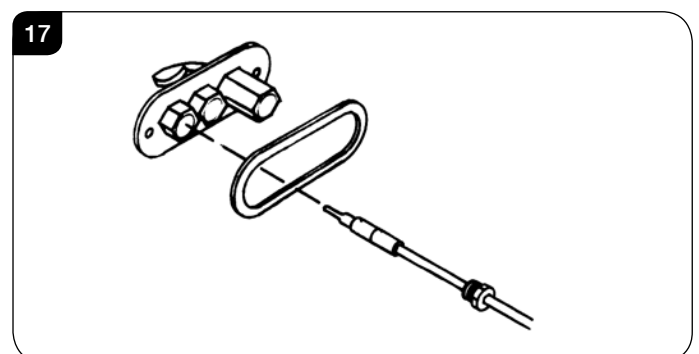



# Servicing Instructions - Replacing Parts

## Gasket

- 5.7 Disconnect all the above components and withdraw the gasket. If it is damaged, replace with a new item. **Always replace the gasket first when reassembling the pilot components.**

## Marlborough2 Medium Only

The pilot assembly consists of 4 components which can be individually changed:

Pilot burner bracket  
Electrode  
Pilot injector  
Thermocouple

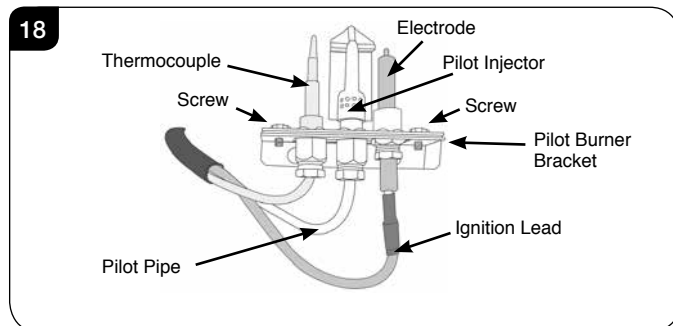

**NOTE: Ensure the sealant surrounding the Electrode and Thermocouple leads is replaced if disturbed or removed whilst gaining access to these components.**

- 5.8 Turn the gas supply off at the isolation device, remove the door and place to one side, carefully remove the ceramic fuel bed components.

## Pilot Burner Bracket

To remove the Pilot Burner Bracket:

- 5.9 **First remove the electrode, pilot pipe and thermocouple as described in the following sections.**
- 5.10 Remove the 2 screws securing the bracket. The pilot burner bracket can now be removed.
- 5.11 Replace in reverse order.

## Electrode

- 5.12 Pull the ignition lead off the electrode and undo the retaining nut, see Diagram 18.
- 5.13 Replace with a new electrode. Do not over-tighten the nut; this could break the component.
- 5.14 Replace the ignition lead by pushing the spade connector onto the terminal (electrode).

## Pilot Injector

- 5.15 Undo the pilot pipe from the gas valve and from the underside of the pilot burner, see Diagram 18.
- 5.16 Remove the pipe and the injector drops out from the burner.

## Thermocouple

- 5.17 Disconnect the thermocouple from the gas valve.
- 5.18 Undo the thermocouple nut in the back of the pilot bracket half a turn. This releases the thermocouple.
- 5.19 When replacing with a new thermocouple, take care to bend the new component to the same shape as the thermocouple just removed.
- 5.20 To refit the thermocouple into the pilot bracket, ensure it is pushed fully into the hole. There is a stop on the thermocouple to set the height.
- 5.21 Lock the retaining nut just enough to grip the thermocouple.
- 5.22 Connect the thermocouple to the valve **taking care not to over-tighten.**

## 6. Ignition Lead

- 6.1 Follow the Pilot Unit instruction to access the back of the pilot assembly.
- 6.2 Disconnect the ignition lead from the electrode.
- 6.3 Remove the front cover from the control valve by removing the retaining screw, see Diagram 19 and gently levering clear with flat bladed screwdriver, see Diagram 20.

**NOTE: There is a small cylindrical metal spacer inside the cover, this must be kept and replaced on the fixing screw on re-assembly.**

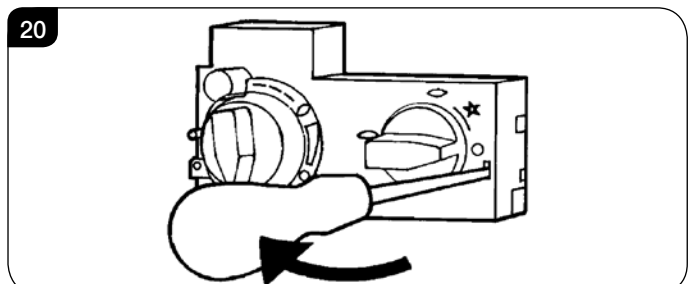
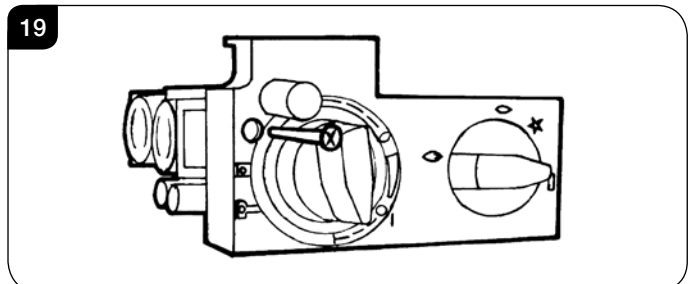

# Servicing Instructions - Replacing Parts

- 6.4 Disconnect the other end of the ignition lead from the valve body noting the route of the ignition lead.
- 6.5 Replace with a new ignition lead following the same route as the old one.  
  
Replace the valve cover and the pilot assembly.
- 6.6 Check operation of the new ignition lead.

## 7. Piezo

- 7.1 The piezo assembly used on this appliance is not serviceable and is not likely to fail.
- 7.2 If a new piezo is required it will be necessary to change the valve, see Section 8.

## 8. Gas Valve

- 8.1 To remove the valve turn off the gas supply at the isolation device.
- 8.2 Disconnect the 2 x 8mm and 1 x 4mm gas pipe fittings at the back of the gas valve, see Diagram 21 (A).
- 8.3 Disconnect the thermocouple, see Diagram 21 (B).

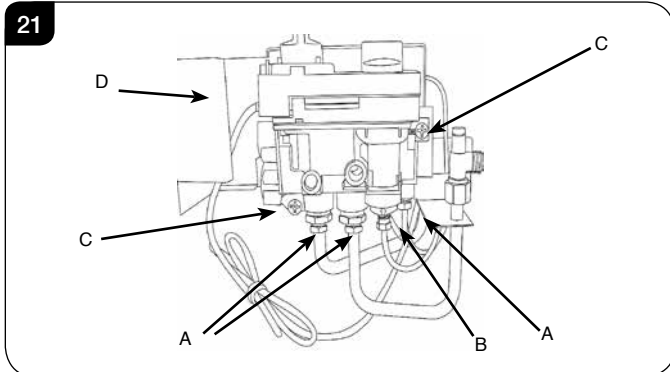

- 8.4 Disconnect the ignition lead from the gas valve, see Diagram 21 (D).
- 8.5 Remove the cover, see Section 6.3.
- 8.6 Undo the two bolts securing the gas valve to the appliance and remove the valve, see Diagram 21 (C).
- 8.7 Replace in reverse order.
- 8.8 Check all joints for gas leaks and check operation of the thermocouple and ignition lead.

## 9. Magnetic Safety Valve

- 9.1 Turn the gas supply off at the isolation device.
- 9.2 Undo the thermocouple connection from the back of the gas valve, Diagram 22 (A).
- 9.3 Undo the magnetic valve-retaining nut from the back of the control valve, see Diagram 22 (B).
- 9.4 Gently tap out the magnetic valve and replace with a new unit.
- 9.5 Replace the retaining nut and tighten.

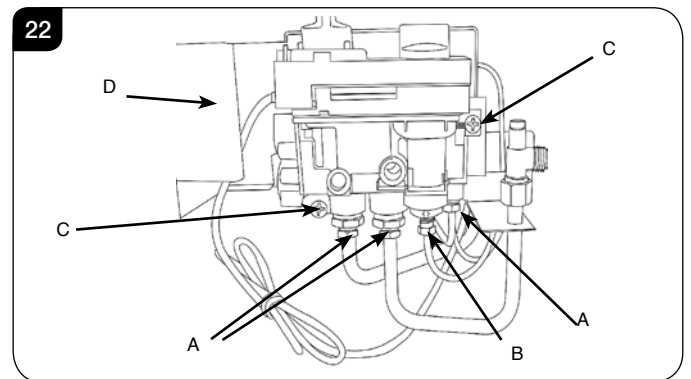

- 9.6 Reassemble the interruptor block and leads and secure the thermocouple connection in the rear of the gas control. (Do not overtighten).
- 9.7 Turn the gas supply on and check the entire pipework and valve joints for any leaks.

## 10. Main Injector

- 10.1 To remove the main injector turn off the gas supply at the isolation device.
- 10.2 Remove the main burner, see Section 4.
- 10.3 Undo the compression nut from the feed pipe at the gas control under the appliance.
- 10.4 Working from inside the firebox remove the lock nut from the injector, see Diagram 23.

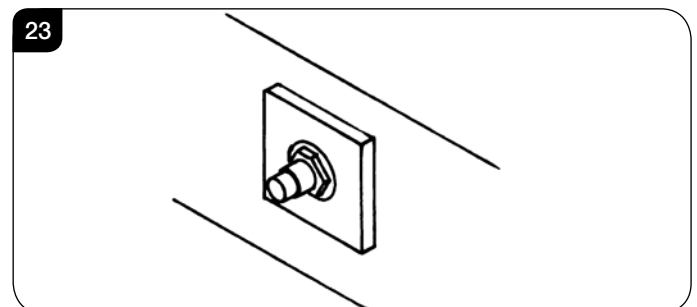

# Servicing Instructions - Replacing Parts

- 10.5 Extract the injector with the feed pipe from beneath the appliance.
- 10.6 Holding the injector with a spanner:
- 10.7 Undo the feed pipe. **Note the orientation of the Injector.**
- 10.8 Re-assemble in reverse order.
- 10.9 Turn on the gas supply and check for leaks.

## 11. Primary Aeration Plate

**NOTE: Not all models have aeration plates. Please refer to the Technical Specification.**

- 11.1 To replace the primary aeration plate turn off the gas supply at the isolation device.
- 11.2 Remove the burner, see Section 4.

### Marlborough2 Small

- 11.3 Remove the fixing screw and slide the plate off the venturi.
- 11.4 Replace with the correct size plate and secure with the screw. Ensure the lower edge of the plate is located over the venturi flange, see Diagram 24.

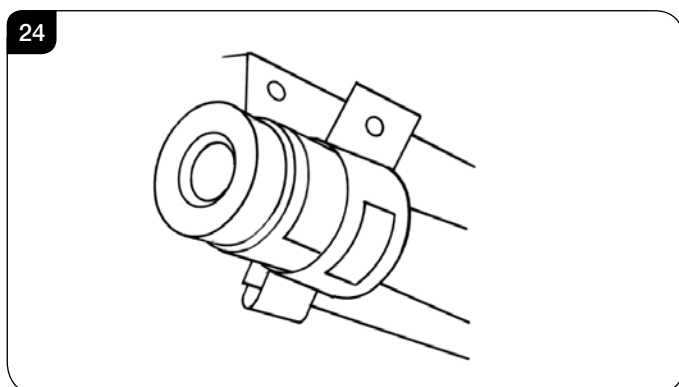

- 11.5 Reassemble in reverse order.  
**NOTE: Even if no aeration plate is required, the small screw must be replaced.**

### Marlborough2 Medium

- 11.6 Remove the fixing nuts and slide the plate off the venturi.
- 11.7 Replace with the correct size plate and secure with the nuts. Ensure the lower edge of the plate is located over the venturi flange, see Diagram 25.

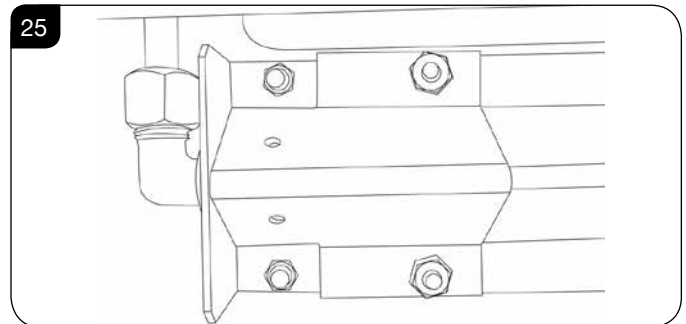

- 11.8 Reassemble in reverse order.

## 12. Changing Between Gas Types

A kit of parts is available for this - Contact your Gazco retailer for further information.

Always quote the Model number and Serial number when ordering any spare parts.

## 13. Control Upgrade

See Installation Instructions, Section 2

# Servicing Instructions - Replacing Parts

## 14. Spare Parts List - Marlborough2 Small

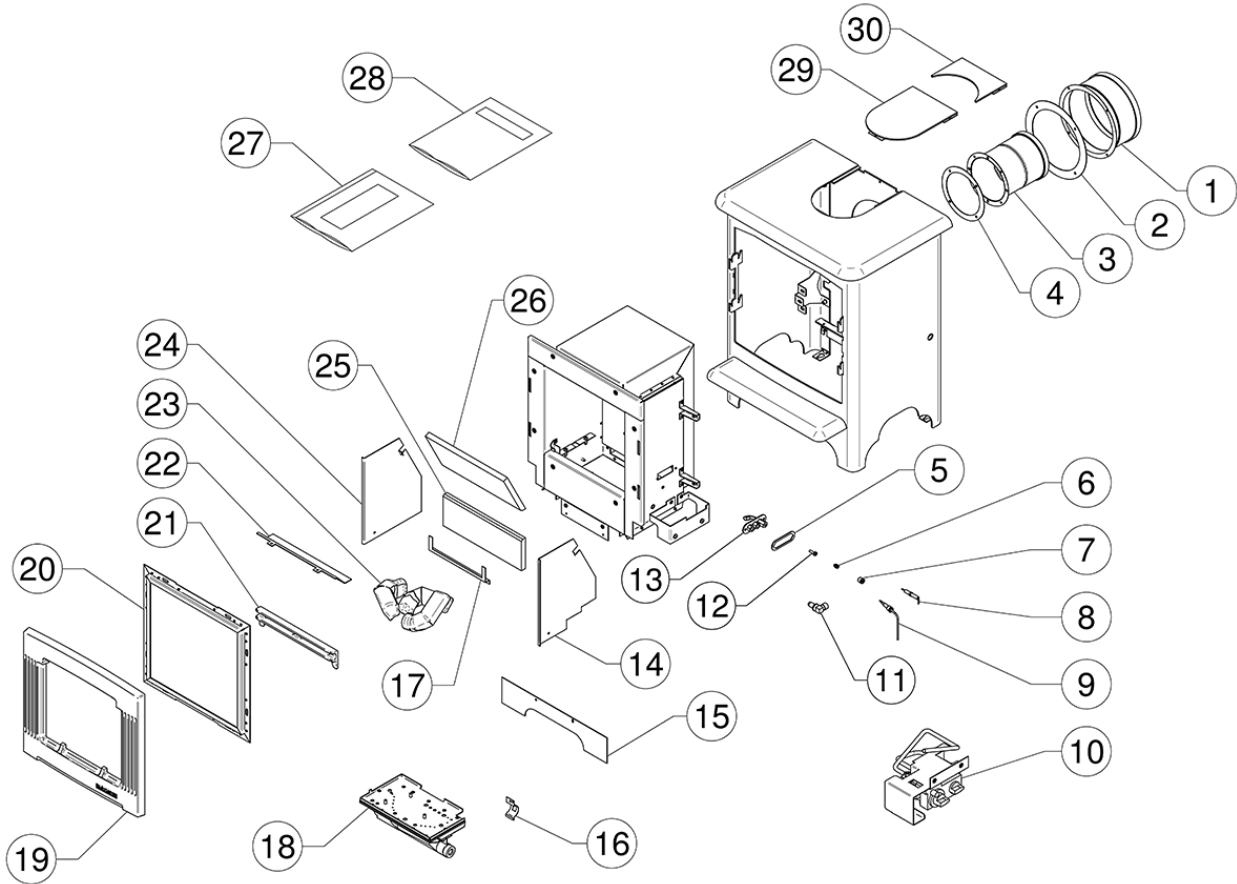

No.	Component	Part Code		Quantity
		Natural Gas	LPG	
1	Outer Spigot	MEC0232		1
2	Outer Spigot Gasket	CE0211		1
3	Inner Spigot	MEC0231		1
4	Inner Spigot Gasket	CE0210		1
5	Pilot Gasket	PI0052		1
6	Hook Olive	PI0013		1
7	Hook Nut	PI0014		1
8	Electrode	PI0053		1
9	Thermocouple	PI0010		1
10	Burner Control Assembly	B0213		1
11	Injector	IN0040	IN0071	1
12	Injector	PI0026	PI0015	1
13	Pilot Burner Body	PI0051		1
14	Reflector - Right Hand	GZ12827		1
15	Vanity Cover	GZ3615		1

No.	Component	Part Code		Quantity
		Natural Gas	LPG	
16	Aeration Plate	GZ3270	GZ3866	1
17	Rear Lining Bracket	GZ13014		1
18	Burner Assembly	GZ12754	GZ12755	1
19	Door Casting	CA0854		1
20	Glass Frame Assembly	GZ14964		1
21	Log Retainer	CA0807		1
22	Top Baffle	GZ13007		1
23	Log Set	CE1559		1
24	Reflector - Left Hand	GZ12828		1
25	Back Panel - Vermiculite	CE1560		1
26	Top Panel - Vermiculite	CE1561		1
27	Embaglow	GZ8471		1
28	Instruction Manual	PR2483		1
29	Flue Blanking Plate	GZ14919		1
30	Flue Infill Plate	GZ14921		1



Due to continual technical improvements please check online or with your Gazco retailer for the most up to date parts lists.

Only use Genuine Gazco spares when servicing your appliance.

All of our essential spare parts and consumable items are available to purchase from our webshop at [www.gazcospares.com](http://www.gazcospares.com).

# Servicing Instructions - Replacing Parts

## 14. Spare Parts List - Marlborough2 Medium

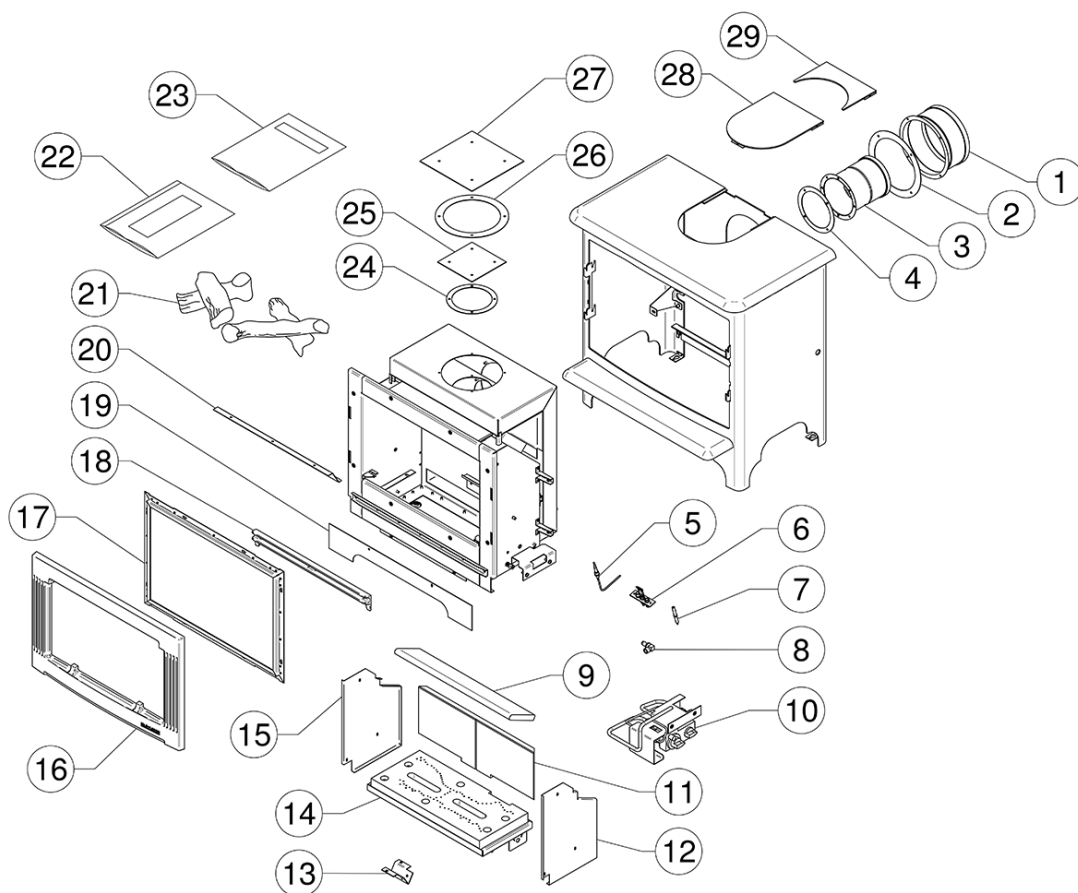

No.	Component	Part Code		Quantity
		Natural Gas	LPG	
1	Outer Spigot	MEC0232		1
2	Outer Spigot Gasket	CE0211		1
3	Inner Spigot	MEC0231		1
4	Inner Spigot Gasket	CE0210		1
5	Thermocouple	PI0074		1
6	Pilot	PI0069	PI0070	1
7	Electrode	PI0075		1
8	Injector	IN0028	IN0040	1
9	Top Liner Panel	CE1312		1
10	Engine Control Assembly	GZ14882		1
11	Rear Liner Panel	CE1311		1
12	Reflector - Right Hand	GZ11015		1
13	Aeration Cover	GZ11217	GZ10411	1
14	Burner Assembly	GZ11001		1
15	Reflector - Left Hand	GZ11014		1

No.	Component	Part Code		Quantity
		Natural Gas	LPG	
16	Door Casting	CA0853		1
17	Glass & Frame Assembly	GZ14965		1
18	Log Retainer	CA0765		1
19	Skirt	GZ3607		1
20	Top Baffle	GZ11544		1
21	Log Set	CE1304		1
22	Embaglow	GZ8471		1
23	Instruction Manual	PR2483		1
24	Inner Spigot Gasket	CE0210		1
25	Inner Box Blanking Plate	GZ1320		1
26	Outer Spigot Gasket	CE0211		1
27	Outer Box Blanking Plate	GZ1321		1
28	Flue Blanking Plate	GZ14813		1
29	Flue Infill Plate	GZ14816		1



Due to continual technical improvements please check online or with your Gazco retailer for the most up to date parts lists.

Only use Genuine Gazco spares when servicing your appliance.  
All of our essential spare parts and consumable items are available to purchase from our webshop at [www.gazcospares.com](http://www.gazcospares.com).

# Servicing Instructions - Replacing Parts

## 14. Spare Parts List - Control Assembly

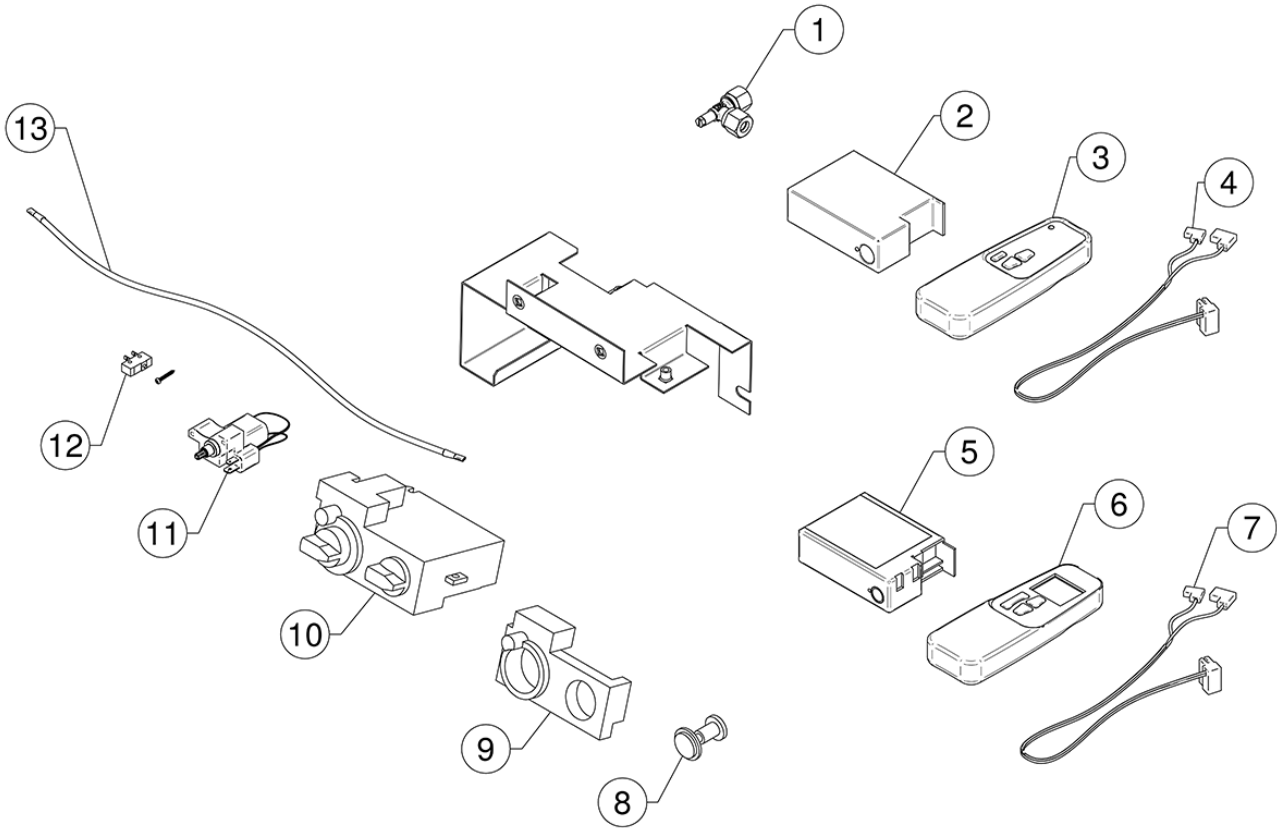

No.	Component	Part Code		Quantity
		Marlborough2 Small	Marlborough2 Medium	
1	Pressure Test Elbow	N/A	IN0009	1
2	Standard Receiver	EL0235		1
3	Standard Handset	EL0239		1
4	Standard Receiver Cable	EL0237		1
5	Thermostatic Receiver	EL0236		1
6	Thermostatic Handset	EL0240		1
7	Thermostatic Receiver Cable	EL0238		1
8	Mag. Unit	GC0166		1
9	Control Valve Cover	GC0087		1
10	Control Valve	GC0088K		1
11	Geared Motor	EL0234		1
12	Micro Switch and Screw	EL0241		1
13	Ignition Lead	GC0090		1



Due to continual technical improvements please check online or with your Gazco retailer for the most up to date parts lists.

Only use Genuine Gazco spares when servicing your appliance.

All of our essential spare parts and consumable items are available to purchase from our webshop at [www.gazcospares.com](http://www.gazcospares.com).

# Service Records

## 1ST SERVICE

Date of Service .....  
Next Service Due .....  
Signed .....  
Retailer's Stamp/GasSafe Registration Number

## 2ND SERVICE

Date of Service .....  
Next Service Due .....  
Signed .....  
Retailer's Stamp/GasSafe Registration Number

## 3RD SERVICE

Date of Service .....  
Next Service Due .....  
Signed .....  
Retailer's Stamp/GasSafe Registration Number

## 4TH SERVICE

Date of Service .....  
Next Service Due .....  
Signed .....  
Retailer's Stamp/GasSafe Registration Number

## 5TH SERVICE

Date of Service .....  
Next Service Due .....  
Signed .....  
Retailer's Stamp/GasSafe Registration Number

## 6TH SERVICE

Date of Service .....  
Next Service Due .....  
Signed .....  
Retailer's Stamp/GasSafe Registration Number

## 7TH SERVICE

Date of Service .....  
Next Service Due .....  
Signed .....  
Retailer's Stamp/GasSafe Registration Number

## 8TH SERVICE

Date of Service .....  
Next Due .....  
Signed .....  
Retailer's Stamp/GasSafe Registration Number

## 9TH SERVICE

Date of Service .....  
Next Service Due .....  
Signed .....  
Retailer's Stamp/GasSafe Registration Number

## 10TH SERVICE

Date of Service .....  
Next Service Due .....  
Signed .....  
Retailer's Stamp/GasSafe Registration Number

# Information Requirement - Gas Heaters

## Information Requirement for Gaseous Fuel Local Space Heater

Model	Marlborough2 Small BF NG	Marlborough2 Small BF LPG	Marlborough2 Medium BF NG	Marlborough2 Medium BF LPG
<b>Fuel</b>	Space Heating Emissions (NOx) - mg / kWh <sub>input</sub> (GCV)	130	130	130

<b>Heat Output</b>	Nominal Heat Output - $P_{nom}$	2.5kW	2.4kW	5.4kW	5.5kW
	Minimum Heat Output (indicative) - $P_{min}$	1.3kW	1.3kW	2.8kW	2.7kW

<b>Auxiliary Electricity Consumption</b>	At Nominal Heat Output - $e_{l,max}$	N/A	N/A	N/A	N/A
	At Minimum Heat Output - $e_{l,min}$	N/A	N/A	N/A	N/A
	In Standby Mode - $e_{l,SB}$	N/A	N/A	N/A	N/A

<b>Useful Efficiency (NCV)</b>	Useful Efficiency at nominal heat output - $\eta_{th,nom}$	85.1%	85.1%	90.8%	90.8%
	Useful Efficiency at minimum heat output (indicative) - $\eta_{th,min}$	72.0%	72.0%	80.0%	80.0%

<b>Permanent Pilot Flame Power requirement</b>	Permanent Pilot Flame Power requirement (if applicable) - $P_{pilot}$	0.200kW	0.200kW	0.200kW	0.200kW
--	---	---------	---------	---------	---------

### Type of heat output/room temperature control

Electronic room temperature control + day timer	Yes	Yes	Yes	Yes
---	-----	-----	-----	-----

### Other control options (multiple selections possible)

Room temperature control, with presence detection	No	No	No	No
Room temperature control, with open window detection	No	No	No	No
With distance control option	No	No	No	No
With adaptive start control	No	No	No	No
With working time limitation	No	No	No	No
With black bulb sensor	No	No	No	No

<b>Energy Efficiency Index</b>	77.0%	77.0%	84.9%	85.0%
<b>Energy Efficiency Class</b>	C*	C*	B*	B*

\*When used with optional Thermostatic Control

<b>Contact:</b>	Gazco Ltd, Osprey Road, Sowton Industrial Estate, Exeter, EX2 7JG
-----------------	---









**Gazco Limited, Osprey Road, Sowton Industrial Estate, Exeter, Devon, England EX2 7JG**  
**Technical Customer Services: (01392) 261950 Fax: (01392) 261951**  
**E-mail: [technicalservices@gazco.com](mailto:technicalservices@gazco.com)**

A member of the Stovax Group  
E & O E