

## OPERATION AND INSTALLATION MANUAL Woodburning and SE models

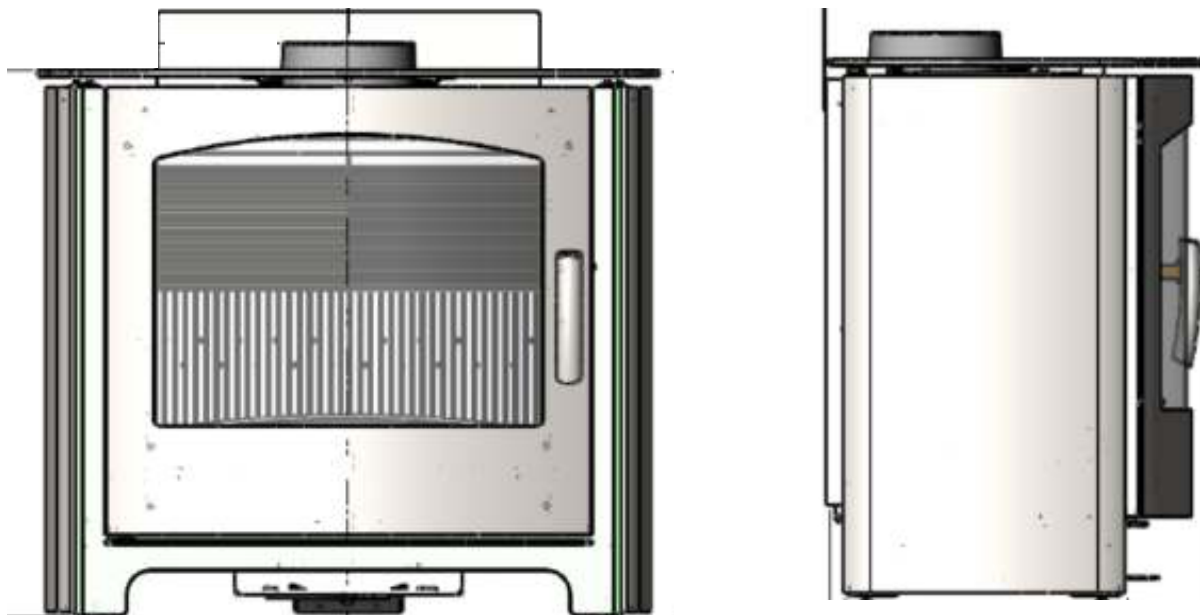

Churchill 10 kW MK4 (SE)

Churchill 10 kW Convection MK4 (SE)

Churchill 10 kW Convection Logstore MK4 (SE)

# Contents



PAGE	ITEM	
2-8	Installation Instructions	ENG
8-15	Operating Guidance	ENG
17-19	Exploded Spare Parts Diagrams	ENG

## MENDIP STOVES 5 YEAR EXTENDED WARRANTY

If you have purchased your stove from a Mendip Stoves registered retailer, then your stove will carry a 2 year warranty as standard. The 2 year warranty can be further extended to a total warranty period of 5 years by registering your Mendip Stove within one month of the latter of the purchase date or installation date. Accordingly, the start date for the warranty period is the date of purchase. During the registration process, the Registered Retailer details will be required for your Extended Warranty to be activated. Any product purchased outside of our registered Retailer Network will carry a standard 12 month, non-extendable warranty. It is a condition of the Extended Warranty that the installation complies with the relevant Building Regulations and is carried out by a suitably trained and qualified individual (HETAS in the UK or equivalent in other countries) with the certificate of installation and proof of purchase supplied. Full terms and conditions are detailed in the Warranty Statement on the Eurostove website [www.eurostove.co.uk](http://www.eurostove.co.uk). In the event of any conflict of information the wording on the website shall prevail. Important Note: Should any problems be experienced with your product, claims must first be submitted to the Retailer where the appliance was purchased from who will offer immediate assistance or contact Eurostove on your behalf.



Register online today to activate warranty: online. <http://www.mendipstoves.co.uk/SIT/StoveRegistration>

Please see the Warranty Card for the complete terms and conditions.

## INSTALLATION MANUAL

CHURCHILL 10 (SE)  
CHURCHILL 10 CONVECTION (SE)  
CHURCHILL 10 CONVECTION LOGSTORE (SE)

This manual refers to the stoves listed above, which are tested in accordance with EN 13240.

Thank you for purchasing your new stove from Mendip Stoves. Please read this manual carefully to ensure that you get maximum enjoyment and performance from your new stove and to prevent any potential operational problems. Please note that "all local regulations, including those referring to national and European Standards, need to be complied with when installing this appliance". For further information on installing and using fireplaces and wood burning stoves, please see the relevant building regulations.

These instructions cover the basic principals to ensure the satisfactory installation of your Wood burning stove, although detail may need slight modification to suit particular local site conditions.

## HEALTH AND SAFETY PRECAUTIONS

---

### INFORMATION FOR THE USER, INSTALLER AND SERVICE ENGINEER

---

Special care must be taken when installing a stove such that the requirements of the Health & Safety at Work Act are met.

#### Handling

Adequate facilities must be available for loading, unloading and site handling.

#### Fire Cement

Some types of fire cement are caustic and should not be allowed to come into contact with the skin. In case of contact wash immediately with plenty of water.

### PREPARATORY WORK AND SAFETY CHECKS

#### IMPORTANT WARNING

This stove must not be installed into a chimney that serves any other heating appliance. There must not be an extractor fan fitted in the same room as the stove because this can cause the stove to emit fumes into the room.

#### Asbestos

This stove contains no asbestos. If there is a possibility of disturbing any asbestos in the course of installation then please seek specialist guidance and use appropriate protective equipment.

#### Metal Parts

When installing or servicing this stove care should be taken to avoid the possibility of personal injury.

#### CO Alarms:-

Building regulations require that whenever a new or replacement fixed solid fuel or wood/biomass appliance is installed in a dwelling a carbon monoxide alarm must be fitted in the same room as the appliance. Further guidance on the installation of the carbon monoxide alarm is available in BS EN 50292:2002 and from the alarm manufacturer's instructions.

**Provision of an alarm must not be considered a substitute for either installing the appliance correctly or ensuring regular servicing and maintenance of the appliance and chimney system.**

#### Stove paint Aerosols

**Paint aerosols are flammable and therefore dangerous to use around a lit stove. Be sure to allow aerosols spray paints to dry and ventilate the room well before lighting the stove. The use of any aerosol around lit stove is dangerous and care must be taken in handling aerosols.**

**Fireguards:** The use of a fireguard to BS 8423:2010 in the presence of children, aged and/or infirm persons is essential for their safety, even when the stove is not in use.

The glass on the stove is ceramic glass and able to withstand very high temperatures however it is not toughened and a hard impact could cause the glass to break.

#### IMPORTANT:

**These instructions cover the basic principles to ensure the satisfactory installation of Mendip Stoves product :- Churchill 10 models, although detail may need slight modification to suit particular local site conditions.**

**In all cases the installation must comply with current Building Regulations, Local Authority Byelaws and other specifications or regulations as they affect the installation of the stove. It should be noted that the Building Regulations requirements may be met by adopting the relevant recommendations given in British Standards BS 8303, BS EN 15287 as an alternative means to achieve an equivalent level of performance to that obtained following the guidance given in Approved Document J.**

## FLUE & CHIMNEY CONNECTION TO STOVE

The outlet from the chimney should be above the roof of the building in accordance with the provisions of Building Regulations Approved Document J. If installation is into an existing chimney then it must be sound and have no cracks or other faults which might allow fumes into the house. Older properties, especially, may have chimney faults or the cross section may be too large .

Mendip Stoves recommend the use of a solid fuel flue lining system for all installation into existing chimneys. All chimney systems must be used in accordance with Building Regulations Approved Document J.

If an existing chimney is used the chimney must be clear of obstruction and be swept clean immediately before installation of the stove. The chimney should be tested to confirm the chimney will provide the correct chimney pressure for the stove. If the stove is fitted in place of an open fire the chimney should be swept one month after installation to clear any soot falls which may have occurred due to the difference in combustion between the stove and the open fire. If there is no existing chimney then either a prefabricated block chimney in accordance with Building Regulations Approved Document J or a twin walled insulated stainless steel flue to BS 1856-1 . These chimneys must be fitted in accordance with the manufacturer's instructions and Building Regulations. A single wall metal flue pipe is suitable for connecting the stove to the chimney but is not suitable for using for the complete chimney.

The Churchill 10 is fitted with a 150 mm collar. These models must be installed with a minimum of a 150mm diameter flue system. Any bend in the chimney or connecting flue pipe should not exceed 45°. 90° bends should not be used other than within 150mm of stove rear flue outlet.

### Chimney Connection

In order for the stove to perform satisfactorily the chimney height must be sufficient to ensure an adequate draught to clear the products of combustion and prevent smoke problems into the room.

Tested Gas flow rates flue gas temperatures	Flue gas flow rate Wood	Test flue gas temperature wood	@ pascals of pressure
Churchill 10	7.9g sec	272 c	12 pa

A chimney height of not less than 4.5 metres measured vertically from the outlet of the stove to the top of the chimney should be satisfactory. Alternatively the calculation procedure given in BS5854:1980 may be used as the basis for deciding whether a particular chimney design will provide sufficient draught.

If it is found that there is excessive draught in the chimney then either an adjustable flue damper or alternately a draught stabiliser should be fitted. The adjustable flue damper should not close off the flue entirely but should in its closed position leave a minimum continuous opening free area of at least 20 % of the total cross sectional area of the flue or flue pipe. Adequate provision e.g. easily accessible soot door or doors must be provided for sweeping the chimney and connecting flue pipe.

Your appliance needs to be maintained routinely, the throat plate/baffle should be cleaned regularly (monthly) . The flue pipe can be cleaned using a flexible brush. Only Use a dry cloth on external surfaces. Over time the glass may become dirty, clean with a damp cloth and polish off with damp cloth. If the stove has not been used for some time the flue should be checked for blockages before use. Do not modify the appliance; only use spares authorised by the manufacturer.

## STOVE PERFORMANCE & TESTING

Mendip Stoves, The Churchill 10 Woodburning models are tested in accordance with EN 13240.

Suitable for DEFRA Smoke Control Zones	Output Wood Fuel	Efficiency	CO@13% O <sub>2</sub>	Particulates @13% O <sub>2</sub>	Nox @13% O <sub>2</sub>	CxHyConc @13% O <sub>2</sub>
Yes	9.5kW	81.0%	0.09	10	90	64

### Weight & Nominal Heat Output for Wood

	Log Length	Wood Reload	Weight Wood Load
Churchill 10	60cm	45min	2kg

### Minimum Distance to Combustible Materials

Combustible materials should not be located where the heat dissipating through the walls of fireplaces or flues could ignite it. Therefore when installing the stove in the presence of combustible materials due account must be taken of the guidance on the separation of combustible material given in Building Regulations Approved Document J and also in these stove instructions. The minimum distances to flammable materials are specified on the EN 13240 plate on the back of the stove.

**When installing the stove 100mm from a combustible wall behind , use the additional, rear convection panel** supplied with the stove, this slots over the rear convection panel providing additional radiant protection from the flue collar. **A twin wall insulated flue should be fitted flush to flue collar for this type of installation.**

Stove Model	Minimum Distance to Combustible Materials		Suitable for 12mm non-combustible floor plate
	REAR	SIDES	
Churchill 10	100mm	500mm	YES
Churchill 10 Convection	100mm	100mm	YES
Churchill 10 Convection Logstore	100mm	100mm	YES

**PLEASE NOTE THAT A MINIMUM DISTANCE OF 1350mm TO SOFT FURNISHINGS SHOULD ALWAYS BE MAINTAINED**

## MINIMUM DISTANCE TO NON-COMBUSTIBLE MATERIALS

The stove can be recessed in a suitable sized non - combustible fireplace but a **permanent free air gap of at least 50mm** must be left around the sides, the top and the back of the stove; this is to facilitate a reasonable heat output and allows access to the stove for removal and maintenance. **A clearance of 100mm will give a better heat output.**

All non - combustible walls closer than 100mm to the stove should be at least 75mm thick. For practical reasons the back wall of the fireplace recess and the hearth should ideally be made of non -combustible material. When installing your stove in a non combustible chamber, combustible materials should not be located where the heat dissipating through the walls of fireplaces or flues could ignite it. Therefore when installing the stove in the presence of combustible materials due account must be taken of the guidance on the separation of combustible material given in Building Regulations Approved Document J and also in these stove instructions. The minimum distances to flammable materials are specified on the EN 13240 plate on the back of the stove.

To ensure that the stove has sufficient air flow available to it during operation, please allow at least 40mm of clearance from the back of the air intake to the rear wall. This means that if you are installing your stove between 50mm and 100mm away from a non - combustible wall, it may be necessary to remove the intake spigot.

## HEARTH

The hearth should be able to accommodate the weight of the stove and its chimney if the chimney is not independently supported. The Churchill stove has been tested and are suitable to be installed on a 12 mm non combustible plate, such as 12 mm glass plates . Installation of all hearths should comply in size and construction so that it is in accordance with the provisions of the current Building Regulations Approved Document J.

The clearance distances to combustible material beneath, surrounding or on the hearth and walls adjacent to the hearth should comply with the guidance on the separation of combustible material given in Building Regulations Approved Document J and also in these stove instructions.

If the stove is to be installed on a wooden floor, it must be covered with a non-combustible material at least **12 mm thick**, in accordance with Building Regulations Approved Document J, to a distance of **30 cm in front of the stove** and **15 cm to each side** measuring from the door of the combustion chamber.

## Fireguards

The use a fireguard to BS 8423:2002 in the presence of children, aged and/or infirm persons is essential for their safety, even when the stove is not in use.

The glass on the stove is ceramic glass and able to withstand very high temperatures however it is not toughened and a hard impact could cause the glass to break.

## STOVE DIMENSIONS AND CONNECTION MEASUREMENTS

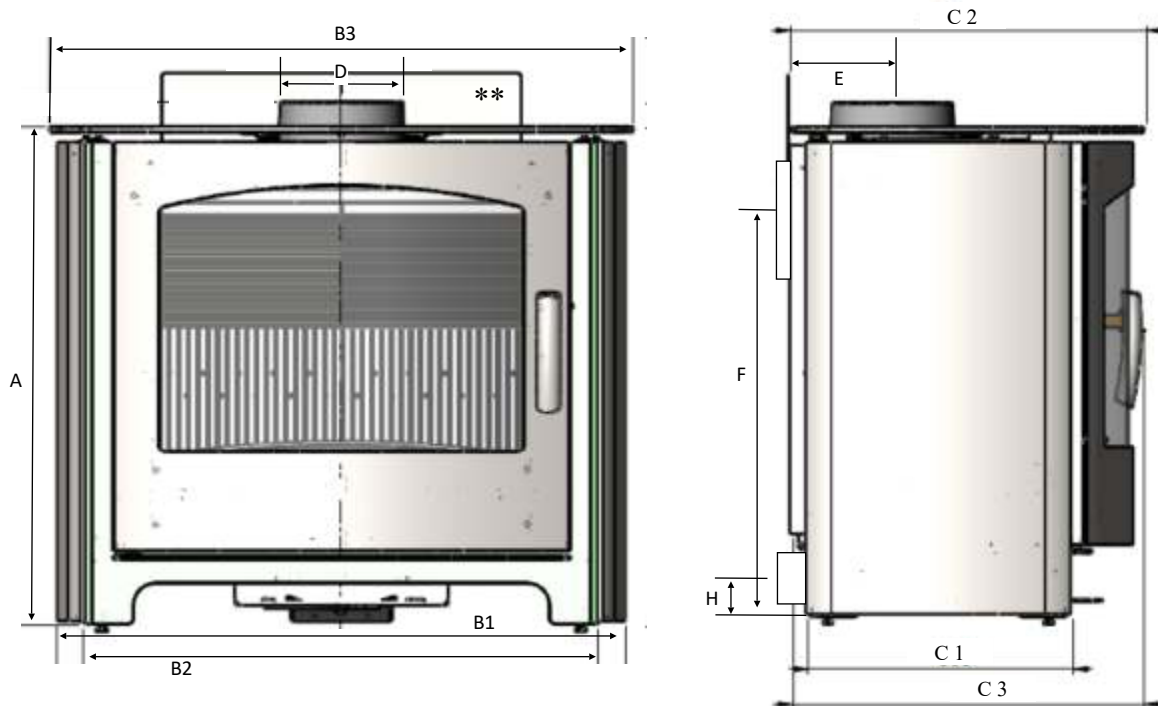

		CHURCHILL 10	CHURCHILL 10 CONVECTION	CHURCHILL 10 CONVECTION LOGSTORE	
<b>HEIGHT</b>	<b>A</b>	665mm	665mm	1052mm	
<b>WIDTH</b>	<b>B1</b>	N/A	759mm	759mm	
	<b>B2</b>	686mm	N/A	N/A	
	<b>B3</b>	696mm	779mm	779mm	
<b>DEPTH</b>	<b>C1</b>	358mm	358mm	358mm	
	<b>C2</b>	482mm	482mm	482mm	
	<b>C3</b>	478mm	478mm	478mm	
<b>DISTANCE FROM / Distance entre</b>	<b>Flue Collar</b>	<b>D</b>	150mm	150mm	
	<b>CENTRE OF FLUE TO REAR OF STOVE</b>	<b>E</b>	142mm	142mm	
	<b>CENTRE OF REAR FLUE OUTLET TO FLOOR</b>	<b>F</b>	564mm	564mm	918mm
	<b>CENTRE OF AIR INTAKE TO FLOOR</b>	<b>H</b>	46mm	46mm	400mm
<b>WEIGHT / Poids</b>	–	110kg	117kg	133kg	

The **direct air intake spigot** (80mm diameter) to the rear of the stove is removable with a 2.5mm Allen key.

\*\* The additional, rear convection panel (supplied loose within the stove) needs to be used when installing the stove 100mm from a combustible wall; this slots over the rear convection panel and provides additional radiant protection from the flue collar.

## COMBUSTION AIR & PERMANENT AIR VENT

In order for the stove to perform efficiently and safely there should be an adequate permanent air supply into the room in which the stove is installed to provide combustion air. This is particularly necessary if the room is double-glazed or a flue draught stabiliser is operating in the same room as the appliance. The provision of air supply to the stove must be in accordance with current Building Regulations Approved Document J. An opening window is not appropriate for this purpose. Air inlets must be positioned in such a way that they cannot be blocked. An air inlet may be a vent (the vent must be open and the capacity for the vent sufficient when the stove is lit) .

Woodland models take all combustion air (primary, secondary & tertiary) from a single 80mm port at the bottom rear of the stove, with the door closed the air port supplies all combustion air for the appliance. This port can be connected to the outside via a 80mm pipe so the appliance does not draw combustion air from the room. However as this stove needs the door to be ajar when lighting and combustion air is taken from the room when reloading. Mendip stoves recommends the use of an additional air vent as laid out in document j .

***The stove requires a permanent air vent to the room . This is to provide adequate air supply in order for the stove to operate safely and efficiently. In accordance with current Building Regulations the installer may have fitted a permanent air supply vent into the room in which the stove is installed to provide combustion air. This air vent should not under any circumstances be shut off or sealed.***

## SE Cleanheat- Smoke Exemption Modification

Smoke exempt (SE) models are factory fitted with an air stop on the air control slider: To adjust the smoke control settings, use an Allen key to adjust the fixing in the air intake (at the rear of the stove).

*Churchill 10 : This stoves requires a restriction of travel of 5mm  
When unrestricted the air control has a travel of 40mm*

The SE fixing is designed to prevent the air supply of the stove from being completely shut off; this promotes complete combustion and therefore acts to decrease harmful pollutants as a result of incomplete combustion.

### **DO NOT OBSTRUCT THE AIR INTAKE**

**At least 40mm clearance should be left between the air intake and the wall**



## COMBUSTION CHAMBERS & FLUE CONNECTION

Mendip Stoves are fitted internally with vermiculite heat deflection panels and baffles, these panels are designed to ensure the maximum efficiency and are an integral part of the clean burn process of the stove. These baffles should not be removed other than for cleaning the stove. Any defective panels should be replaced, (small hairline cracks do not need replacement) however can develop during long term use to a larger crack, if this passes through the vermiculite to the stove body then the panel must be replaced. When refuelling your stove place the wood fuel into the chamber (wearing a glove), impact from logs can cause the heat deflection panel to crack.

### **Connection to chimney**

Mendip Stoves are built with a top flue outlet as standard, this can be altered to a rear connection by removing the top collar, rear cover plate then exchanging collar and plate. Care should be taken to ensure an airtight fit when refitting collar and plate. When installing a rear flue exit model please remove rear cleaning steel plate inside the flue collar box.

A decorative cover plate is included in each stove to cover the hole in the convection top plate. This collar allows connection to either a masonry chimney or a prefabricated factory made insulated metal chimney.

## COMMISSIONING AND HANDOVER

Ensure all loose parts (bricks and grates) are fitted in accordance with the instructions given in the instruction booklet. On completion of the installation allow a suitable period of time for any fire cement/silicon and mortar to cure, a small fire may be lit to check that smoke and fumes are taken from the stove up the chimney and emitted safely into the atmosphere.

***Do not run at full output for at least 24 hours after this appliance has been installed.***

On completion of the installation and commissioning ensure that the operating instructions for the stove are left with the customer. Ensure to advise the customer on the correct use of the appliance with the fuels likely to be used in the stove and notify them to use only the recommended fuels for the stove. Advise the user what to do should smoke or fumes be emitted from the stove. The customer should be warned to use a fireguard to BS 8423:2010 in the presence of children, aged and/or infirm persons.



## OPERATING YOUR STOVE - THE MK.4 AIR CONTROL LEVER

The Universal air controller provides air control for the whole stove from a single lever. The Lever has two key operations

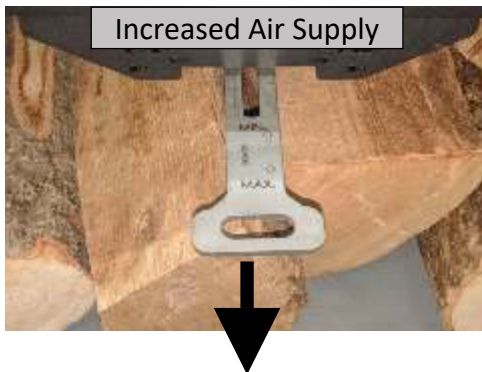

**Moving the control lever in and out**  
Sliding the control lever in reduces and out increases the total amount of combustion air in the stove.



Whatever position the control is set at, the lever can have either minimum combustion air or maximum combustion air.

**Moving the control lever from left to right:**  
By moving the control lever to the left increases the primary air mix and moving to the right increases secondary air (airwash) mix.



## LIGHTING YOUR STOVE FOR THE FIRST TIME

**Before lighting your stove for first time make sure you have read this manual fully and acquainted yourself with the controls of this appliance.**

Ensure that you have allowed sufficient time for the heat resistant sealant to cure.

The heat-resistant paint on your stove will cure and harden the first time you light your appliance.

The curing process produces a good deal of smoke and odour, it is therefore important that the first time you light your stove the room should be well ventilated.

During the process **it is important to open and close the stove door periodically** (every 30mins) during the first couple of firings therefore preventing the door seal cord around the door from sticking and coming away from the door. Once the heat-resistant paint has hardened the smell will disappear.

**Your stove is NOT designed to be used with the door open**, the stove door must be kept closed except when lighting the stove, adding firewood or removing ash in order to prevent flue gases from escaping.

### Use of Fire lighters

Quality Firelighters should be used when lighting your stove. (Never use mentholated spirit, petrol or other flammable liquids). Lighting your stove with firelighters will be more reliable and easier than using paper. Lighting your fire with paper results in excess smoke, more ash and possible blackening of glass.

## HOW TO LIGHT YOUR WOODBURNING STOVE

1.

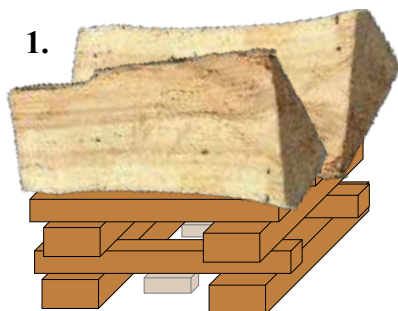

Arrange your Kindling & Logs as shown

**Note: If the chimney is externally fitted or the stove has been installed on a larger diameter clay chimney liner then on cold days it maybe necessary to warm the flue using firelighters prior to lighting with wood.**

1. Place a few smaller pieces of dry wood (kindling) in the stove on top of the non toxic firelighters, place one or two small dry split logs ( $\frac{1}{4}$  split) on top. Kindling stacked as in diagram allows combustion air flow freely and will aid ignition.

2.



Full Primary Air

2. Position the Universal Air Control (UAC) lever below the stove door so that is to the left and fully open (pulled out); this provides the stove with a mix of primary and secondary air to help establish the fire.

3. Light the firelighters and push door to closed position, latch in 1st position so the door is open 2 mm. (see picture) This provides additional combustion air for start up and reduces condensation on the door glass.

3.



Door Ajar to Aid Start-up

4. Once the flames from the logs are fully established, this can take up to 10 min's. The door can now be closed. Slide the UAC control in the middle position. If the stove flames begin to falter and generate smoke in chamber unlatch the door again until the fire is fully established.

5. Once the fire bed is established slide UAC control to the secondary position and push in slider by 50%, for the stove to burn cleanly plenty of secondary air is needed, do not be tempted to shut the fire down too early as this may cause smoke. At nominal heat output, expect to refuel your stove approximately once an hour. Check load weights for your model on the table on page 6.

*Use the glove when operating air controls and door.*

4.



Full Air Supply in Central Position

5.



Reduced Air Supply in Secondary Position

**The stove will get very hot during use, therefore due care must be exercised. Please use the glove when operating air controls, door and ash pan.**

### WOOD FUEL

Good quality wood is the most important factor in your stove working efficiently and cleanly. Always use dry split hardwood firewood (moisture content of 20% or less). The dryness of the firewood plays an important role because the use of wet wood results in poor fuel economy and may cause a tarry sooty film on the internals of the stove.

Newly cut wood contains 60–70% water, making it totally unsuitable for use as firewood; it should be stacked and air dried under cover for two years before being used as firewood.

**Do not burn liquid fuels, drift wood, finished, sawn wood, pallet wood, chipboard/plywood, varnished wood or plastic coated wood, wood treated with preservatives, or house hold waste.**

## WARNING NOTE

Properly installed, operated and maintained this stove will not emit fumes into the dwelling. Occasional fumes from de-ashing and re-fuelling may occur. However, persistent fume emission is potentially dangerous and must not be tolerated. If fume emission does persist, then the following immediate action should be taken:-

- (a) Open doors and windows to ventilate the room and then leave the premises.
- (b) Let the fire go out.
- (c) Check for flue or chimney blockage and clean if required
- (d) Do not attempt to relight the fire until the cause of the fume emission has been identified and corrected. If necessary seek expert advice.

The most common cause of fume emission is flue way or chimney blockage. For your own safety these must be kept clean at all times.

### CO Alarm

Your installer should have fitted a CO alarm in the same room as the appliance. If the alarm sounds unexpectedly, follow the instructions given under "Warning Note" above.

### Aerosols

**Aerosols are flammable and therefore dangerous to use around a lit stove. Do not use aerosols sprays near your lit stove. The use of any aerosol is dangerous and care must be taken in handling aerosols.**

## OPERATING YOUR STOVE

**Suitable fuels:-** Your stove is tested to burn wood. Wood briquettes can also be burnt but special account should be taken of fuel weight. For a full list of suitable fuels, check with the official solid fuels approvals body, HETAS or Solid Fuel association. Do not overload stove as this can cause excessive heat and damage the stove (see table on page 6).

**ALWAYS KEEP FUEL LOAD BELOW TERTIARY PORTS AT REAR OF STOVE. Only use fuels approved for use on heating stoves. Do not burn liquid fuels, drift wood, finished wood, sawn wood, pallet wood, chipboard/plywood, varnished wood or plastic coated wood, wood treated with preservatives, or any household waste.**

**DO NOT EXCEED SPECIFIED FUEL WEIGHTS (SEE pg.6).**

**DO NOT RUN AT FULL OUTPUT FOR EXTENDED PERIODS OF TIME.**

**DO NOT BURN HOUSE COAL. DO NOT BURN HOUSEHOLD WASTE.**

**THIS APPLIANCE IS NOT AN INCINERATOR.**

**MENDIP STOVES RECOMMEND THE USE OF A FLUE THERMOSTAT TO CHECK YOUR STOVE IS NOT OVERHEATING. PLACE FLUE THERMOSTAT DIRECTLY ABOVE COLLAR OF STOVE AND REFER TO TEMPERATURE GAUGE ON PAGE 5.**

**AS THE APPLIANCE WILL BECOME VERY HOT.**

**HOUSE COAL AND PETROLEUM COKE ARE NOT SUITABLE FOR USE ON THIS STOVE; ITS USE WILL INVALIDATE THE GUARANTEE.**

## OVERNIGHT BURNING

Mendip Stoves do not recommend Mendip stoves do not recommend that their stoves are burnt overnight.

## RE-FUELLING WHEN BURNING WOOD

Adding fuel to your stove when you **only have glowing embers**, and the flames have died down, is the cleanest way to refuel your stove.

1. Before refuelling, open the Universal Air Control (UAC) fully and slide to the central position.
2. Unlatch the door to equalise the pressure inside the stove with that of the room.
3. Then, open the door gently.
4. If it is necessary, use a poker to create a level bed before adding a piece of wood below the level of the tertiary air ports (please check weight table page 6).
5. Now, close the door.
6. Once the flames are fully established, slide the UAC lever to the right (secondary air / airwash) and half way in (50% air supply).

Please regard these instructions as guidelines because each installation will be slightly different. Experience will determine the settings that produce best results.

To prevent overheating your appliance we recommend that you use a flue thermostat (placed on a non insulated section of pipe directly above the collar of the stove).

**The efficient operating temperature range is between 180°C and 250°C**

These stoves are not designed to run overnight or for long periods unattended (see pg.14)

## INCOMPLETE COMBUSTION

Incomplete combustion may lead to a build-up of hard, shiny soot on the inside of your stove and glass. It is generally the results of an insufficient air supply to the combustion chamber. If you find that this build-up is occurring to your Mendip Stove, you should:

1. Increase the amount of secondary air used when running the stove,
2. Check that the fuel you use is suitable and dry (less than 20% moisture content).
3. Check that your flue system (chimney) is producing sufficient draught.

It is important to check the draft conditions before lighting your stove. This may be done, for instance, by crumpling a piece of newspaper, placing it in the combustion chamber and lighting it. The draft conditions are good if the smoke is drawn away through the chimney.

## TROUBLE SHOOTING

### 1. Fire Will Not Burn - check

- a) the air inlet is not obstructed in any way,
- b) that chimney and flue ways are clear,
- c) that a suitable fuel is being used,
- d) that there is an adequate air supply into the room,
- e) that an extractor fan is not fitted in the same room as the fire.

### 2. Fire Blazing Out Of Control - check

- a) the doors are tightly closed,
- b) the air controls are turned down to the minimum setting,
- c) the flue damper is closed ( if fitted),
- d) a suitable fuel is being used,
- e) the door seals are in good condition.
- f) the chimney draft may be too strong
- g) check ash pan seal and
- h) check for ash below ash pan causing pan to seat incorrectly and clean out.

### 3. Soot forms on the window

- a) The firewood may be too wet
- b) the intake of secondary air may be insufficient
- c) fire not hot enough

### 4. The stove fails to heat fully

- a) The firewood may be too wet
- b) the intake of secondary air may be insufficient

### 5. Smoke or odour

- a) weak chimney draft
- b) check for blockages in the flue pipe/chimney
- c) check the height of the chimney relative to the surroundings

### 6. Soot in the chimney

- a) The firewood may be too wet
- b) intake of secondary air may be insufficient



## MAINTENANCE

Mendip stoves recommends that your model needs to have the ash removed from the stove at regular intervals (weekly if used daily). Allowing the ash pan to over flow can impede the function of the stove and can cause possible damage to the stove grate and ash pan. To remove ash pan use heat protecting glove provided. Lift and pull out of firebox chamber. Take care to support ash pan during movement. Make sure the stove is completely cold before cleaning out ash (embers can remain hot for over 24 hours).

Ash must be stored in a non-combustible container and must not be mixed with other combustible waste.

### Annual service

The stove should be serviced by a registered dealer once a year. The stove, the flue pipe connection and the chimney should be checked regularly by a qualified engineer. The chimney should also be checked for blockages before relighting the stove if it has not been used for an extended period of time. Insulating fire bricks checked for wear and replaced if necessary door and ashpan rope seals should be changed annually, glass clamps & glass should be checked making sure glass is correctly positioned.

To clean the inside the stove, remove all ash, soot and tar residue from the combustion chamber. Remove insulated chamber panels and baffle, dirt and soot will collect behind it and this must be cleaned out. The paint/ lacquer can wear thin in exposed places due to overheating. This, and other lacquer damage, may be repaired using Senotherm paint/lacquer spray available from your Mendip dealer. To clean the outside of the stove use a dry cloth.

Your stove should be serviced annually by a registered dealer as a condition of the extended warranty of the stove, failure to maintain a service record will invalidate the extended warranty on your stove.

### Prolonged non use (summer)

If the stove is to be left unused for a prolonged period of time (e.g. over the summer) then it should be given a thorough clean to remove ash and unburned fuel residues. To enable a good flow of air through the appliance to reduce condensation and subsequent damage, leave the air controls fully open.

It is important that the flue connection, any appliance baffles or throat plates and the chimney are swept prior to lighting up after a prolonged shutdown period.

### Spare parts & unauthorised alterations

Only the manufacturer's own components, or replacement parts recommended and approved by Mendip stoves, shall be used for appliance servicing and repair. Any unauthorised alterations will invalidate the stove warranty and compliance with EN13240.

## SWEEPING YOUR CHIMNEY & CHIMNEY FIRES

Ensure that your appliance, flue ways and chimney are swept regularly. This can be incorporated in the service regime of your appliance. Regular sweeping is essential and it is recommended twice a year for wood stoves. If a throat plate is incorporated, it is essential that the throat plate is removed and cleaned above, all ash and debris should be removed. Ensure adequate access to cleaning doors where it is not possible to sweep the chimney through the appliance.

Where a chimney has served an open fire installation previously it is possible that the higher flue gas temperature from a closed appliance may loosen deposits that were previously firmly adhered, with the consequent risk of flue blockage. It is therefore recommended that the chimney be swept a second time within a month of regular use after installation of the stove.

### Chimney Fires

If the chimney is thoroughly and regularly swept, chimney fires should not occur. However, if a chimney fire does occur turn the air control setting to the minimum, and tightly close the doors of the stove. This should cause the chimney fire to go out in which case the control should be kept at the minimum setting until the fire in the stove has gone out. The chimney and flue ways should then be cleaned. If the chimney fire does not go out when the above action is taken then the fire brigade should be called immediately.

After a chimney fire the chimney should be carefully examined for any damage. Expert advice should be sought if necessary

## BURNING WOOD IN A SMOKE CONTROL AREA

You must purchase a smoke exempt version of a Mendip Stove; this will be modified slightly to comply with regulations. Any alteration to this modification will invalidate the stoves compliance for smoke control areas.

### The Clean Air Act 1993 and Smoke Control Areas

Under the Clean Air Act local authorities may declare the whole or part of the district of the authority to be a smoke control area. It is an offence to emit smoke from a chimney of a building, from a furnace or from any fixed boiler if located in a designated smoke control area. It is also an offence to acquire an "unauthorised fuel" for use within a smoke control area unless it is used in an "exempt" appliance ("exempted" from the controls which generally apply in the smoke control area).

In England appliances are exempted by publication on a list by the Secretary of State in accordance with changes made to sections 20 and 21 of the Clean Air Act 1993 by section 15 of the Deregulation Act 2015. Similarly in Scotland appliances are exempted by publication on a list by Scottish Ministers under section 50 of the Regulatory Reform (Scotland) Act 2014. In Wales and Northern Ireland these are authorised by regulations made by Welsh Ministers and by the Department of the Environment respectively.

**Further information on the requirements of the Clean Air Act can be found here:**

<https://www.gov.uk/smoke-control-area-rules>

Your local authority is responsible for implementing the Clean Air Act 1993 including designation and supervision of smoke control areas and you can contact them for details of Clean Air Act requirements.

The Churchill 10 Mk.4 SE stoves have been recommended as suitable for use in smoke control areas when burning wood logs. More information regarding authorised fuels can be found at <http://smokecontrol.defra.gov.uk/fuels.php>.

The SE appliances include a modified air control to prevent closure of the secondary air control, **alterations should not be attempted**. Mendip Stoves smoke control stoves should not be burnt with the door left open.:-

***Churchill 10 : This stoves requires a restriction of travel of 5mm***

***When unrestricted the air control has a travel of 40mm***

### The refuelling procedure :

Allow the newly charged fuel to burn with the secondary air control set at maximum for up 3 to 4 minutes. After this period, with flames from the logs fully established, close the secondary air supply to the low output setting. When operating at high output (secondary air set fully open) the new refuel charge does not require any boost air to establish combustion.

### Refuelling on to a low fire bed

If there is insufficient burning material in the fire bed to light a new fuel charge, excessive smoke emission can occur. Refuelling must be carried out onto a sufficient quantity of glowing embers and ash that the new fuel charge will ignite in a reasonable period. If there are too few embers in the fire bed, add suitable kindling to prevent excessive smoke.

### Fuel Overloading

The maximum amount of fuel specified in this manual should not be exceeded, overloading can cause excess smoke.

### Air controls & doors left open

Operation with the air controls fully open can cause excess smoke. The appliance must not be operated with air controls, appliance dampeners or the door left open except as direct in the instructions.

## CHURCHILL10 MK.4 COMBUSTION CHAMBER

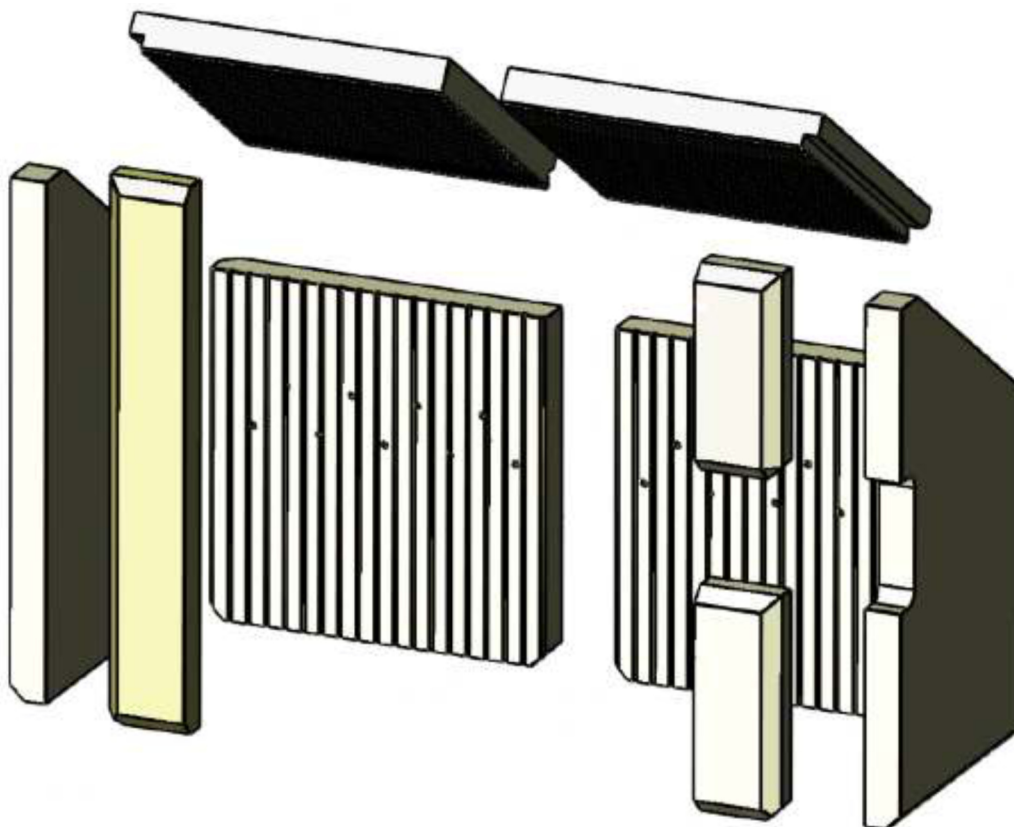

### VERMICULITE BRICKS REFERENCE TABLE

CODE	DESCRIPTION	PARTS / LES PIÈCES
Churchill 10		
M90036-02-00-99-05	Full Brick Set - CHU/LOX 10 Mk.4	9
M90036-02-23-99-02	Rear Brick Pair	2
M90036-02-24-99-04	Side Brick Set (Inc. 3 x front bricks)	5
M90036-02-26-99-02	Baffle Brick Pair	2

To find out more details, as well as to get prices and availability of these parts, please visit:

[www.eurostove.co.uk/mp-lox-chu-10-mk4-spare-bricks](http://www.eurostove.co.uk/mp-lox-chu-10-mk4-spare-bricks)



## HOW TO REMOVE THE WOOD BURNERS INTERNAL PARTS



To remove the vermiculite brick set take the following steps:

Remove both of the vermiculite baffle bricks by lifting and tilting each brick in turn.



To create more room to remove the first brick, lift up the adjacent baffle and rest a larger amount on the side brick.



It is now possible to remove both side bricks;

You may find it easier to remove the cast iron grate before removing the side bricks.

Finally, remove both rear bricks.



To remove upper steel baffles/ turbulence plates

Firstly lift the upper, ribbed, turbulence plate, slide forwards towards the front of the stove.

This will create enough space to allow the plate drop down so that the baffle can be removed.



To remove rear steel baffle is Simply push this away from the holding frame, which it rests on, and twist it to fit through the opening.

You now have access to the flue system, whether the collar is situated on the top or to the rear of your stove.



# CHURCHILL MK.4 DOOR ASSEMBLY

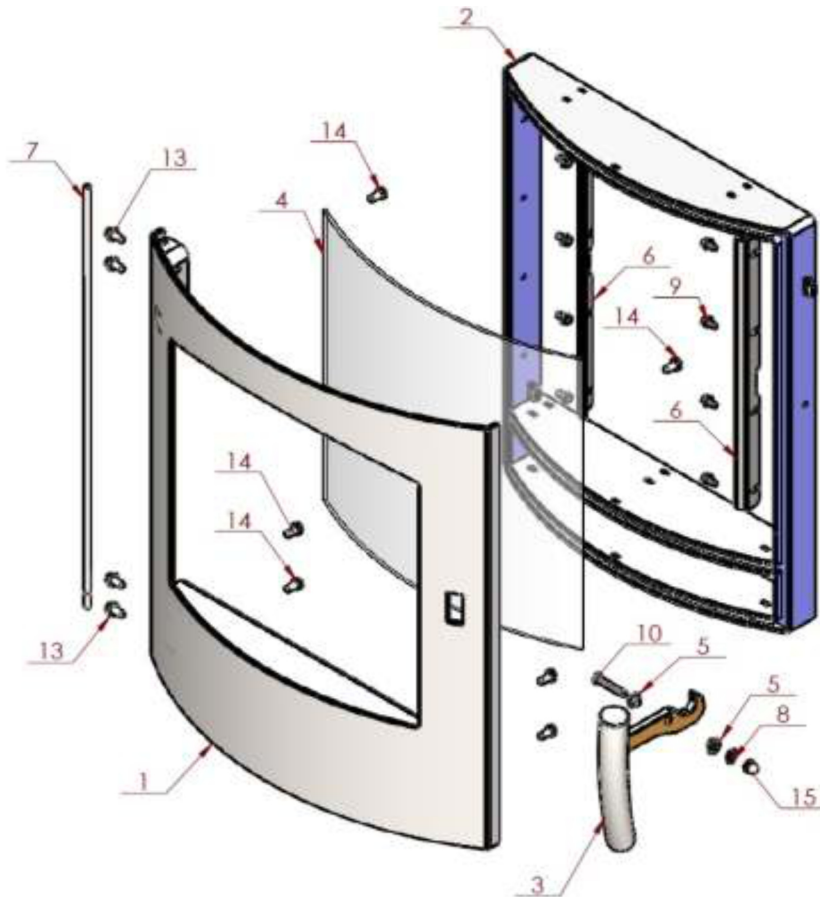

## STOVE PARTS, COMBUSTION CHAMBER, ASSEMBLY

"This section shows the parts contained in your stove, each stove has over 80 spare-parts and, each part is detailed. When new parts are required the section will allow spares to be recognised and ordered. As a further source of reference please visit [www.eurostove.co.uk](http://www.eurostove.co.uk) for latest spare-part information.

### LOOSE PARTS

Always use the operating tools provided when handling parts likely to be hot when the stove is in use. Your stove has the following parts in the stove.

- 1) Cast Iron grate & log retainer .
- 2) Ashpan
- 3) Stove Glove
- 4) Top plate decorative cover plate.
- 5) Instruction manual & warranty card
- 6) Vermiculite brick linings ( these are integral to the stoves performance-Do not throw away)
- 7)Moisture absorbency bag



### COMBUSTION CHAMBER



Secondary air /air wash

Tertiary Air

Vermiculite brick set

Cast iron grate

Log retainer

Ash pan with handle



# Mendip Stoves

**Mendip Stoves Ltd.**

Unit H1  
Mendip Industrial Estate  
Mendip Road  
Rooksbridge  
Somerset  
**BS26 2UG**

**Website**

[www.mendipstoves.co.uk](http://www.mendipstoves.co.uk)

**Email**

[info@eurostove.co.uk](mailto:info@eurostove.co.uk)

**Telephone**

01934 750 500



0691046762047